

**POST DEVEL**

Prepared by Fuller Engineering & Land Surveying, LLC  
HydroCAD® 10.00 s/n 02123 © 2011 HydroCAD Software Solutions LLC

#245 Route 32 Montville, CT  
Type III 24-hr 25-YEAR Rainfall=6.15"

Printed 3/15/2022

Page 23

**Reach 1R: DROP MANHOLE**

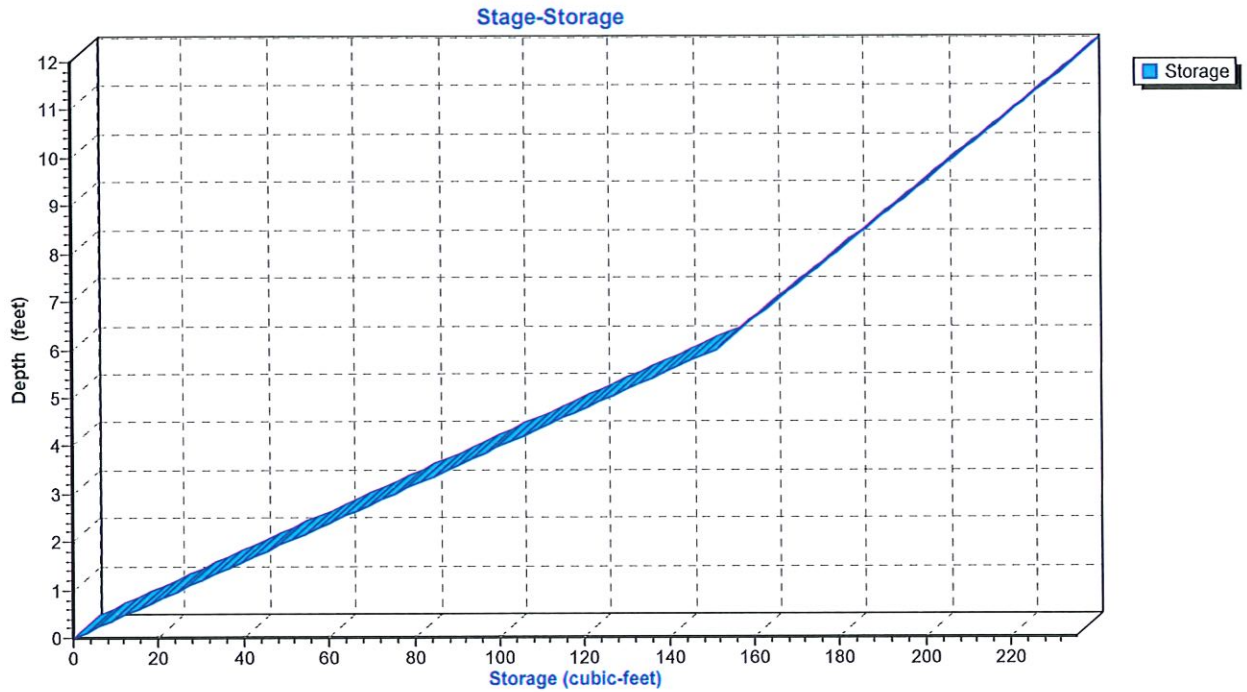

**POST DEVEL**

Prepared by Fuller Engineering & Land Surveying, LLC

Printed 3/15/2022

HydroCAD® 10.00 s/n 02123 © 2011 HydroCAD Software Solutions LLC

Page 24

**Hydrograph for Reach 1R: DROP MANHOLE**

Time (hours)	Inflow (cfs)	Storage (cubic-feet)	Elevation (feet)	Outflow (cfs)
0.00	0.00	0	61.16	0.00
0.50	0.00	0	61.16	0.00
1.00	0.00	0	61.16	0.00
1.50	0.00	0	61.16	0.00
2.00	0.00	0	61.16	0.00
2.50	0.00	0	61.16	0.00
3.00	0.00	0	61.16	0.00
3.50	0.00	0	61.16	0.00
4.00	0.00	0	61.16	0.00
4.50	0.00	0	61.16	0.00
5.00	0.00	0	61.16	0.00
5.50	0.00	0	61.16	0.00
6.00	0.00	0	61.16	0.00
6.50	0.00	0	61.16	0.00
7.00	0.00	0	61.16	0.00
7.50	0.00	0	61.16	0.00
8.00	0.00	0	61.16	0.00
8.50	0.00	0	61.16	0.00
9.00	0.00	0	61.16	0.00
9.50	0.00	0	61.16	0.00
10.00	0.00	0	61.16	0.00
10.50	0.00	0	61.16	0.00
11.00	0.00	0	61.16	0.00
11.50	0.00	0	61.16	0.00
12.00	0.00	0	61.16	0.00
12.50	<b>1.10</b>	<b>0</b>	<b>61.17</b>	<b>1.09</b>
13.00	<b>1.34</b>	<b>0</b>	<b>61.17</b>	<b>1.34</b>
13.50	0.57	0	61.16	0.57
14.00	0.26	0	61.16	0.26
14.50	0.16	0	61.16	0.17
15.00	0.11	0	61.16	0.11
15.50	0.06	0	61.16	0.06
16.00	0.02	0	61.16	0.02
16.50	0.00	0	61.16	0.00
17.00	0.00	0	61.16	0.00
17.50	0.00	0	61.16	0.00
18.00	0.00	0	61.16	0.00
18.50	0.00	0	61.16	0.00
19.00	0.00	0	61.16	0.00
19.50	0.00	0	61.16	0.00
20.00	0.00	0	61.16	0.00
20.50	0.00	0	61.16	0.00
21.00	0.00	0	61.16	0.00
21.50	0.00	0	61.16	0.00
22.00	0.00	0	61.16	0.00
22.50	0.00	0	61.16	0.00
23.00	0.00	0	61.16	0.00
23.50	0.00	0	61.16	0.00
24.00	0.00	0	61.16	0.00

**POST DEVEL**

Prepared by Fuller Engineering & Land Surveying, LLC

Printed 3/15/2022

HydroCAD® 10.00 s/n 02123 © 2011 HydroCAD Software Solutions LLC

Page 25

**Stage-Discharge for Reach 1R: DROP MANHOLE**

Elevation (feet)	Velocity (ft/sec)	Discharge (cfs)	Elevation (feet)	Velocity (ft/sec)	Discharge (cfs)
61.16	0.00	0.00	68.96	105.55	1,551.54
61.31	99.87	31.46	69.11	105.98	1,576.44
61.46	99.87	62.92	69.26	106.40	1,601.39
61.61	99.87	94.38	69.41	106.82	1,626.41
61.76	99.87	125.84	69.56	107.24	1,651.49
61.91	99.87	157.29	69.71	107.65	1,676.64
62.06	99.87	188.75	69.86	108.05	1,701.84
62.21	99.87	220.21	70.01	108.45	1,727.10
62.36	99.87	251.67	70.16	108.85	1,752.42
62.51	99.87	283.13	70.31	109.23	1,777.80
62.66	99.87	314.59	70.46	109.62	1,803.23
62.81	99.87	346.05	70.61	110.00	1,828.72
62.96	99.87	377.51	70.76	110.37	1,854.25
63.11	99.87	408.97	70.91	110.74	1,879.85
63.26	99.87	440.42	71.06	111.11	1,905.50
63.41	99.87	471.88	71.21	111.47	1,931.19
63.56	99.87	503.34	71.36	111.82	1,956.93
63.71	99.87	534.80	71.51	112.18	1,982.73
63.86	99.87	566.26	71.66	112.52	2,008.57
64.01	99.87	597.72	71.81	112.87	2,034.46
64.16	99.87	629.18	71.96	113.21	2,060.40
64.31	99.87	660.64	72.11	113.54	2,086.38
64.46	99.87	692.10	72.26	113.88	2,112.41
64.61	99.87	723.55	72.41	114.20	2,138.48
64.76	99.87	755.01	72.56	114.53	2,164.59
64.91	99.87	786.47	72.71	114.85	2,190.76
65.06	99.87	817.93	72.86	115.17	2,216.96
65.21	99.87	849.39	73.01	115.48	2,243.20
65.36	99.87	880.85	73.16	115.79	2,269.48
65.51	99.87	912.31			
65.66	99.87	943.77			
65.81	99.87	975.22			
65.96	99.87	1,006.68			
66.11	99.87	1,038.14			
66.26	99.87	1,069.60			
66.41	99.87	1,101.06			
66.56	99.87	1,132.52			
66.71	99.87	1,163.98			
66.86	99.87	1,195.44			
67.01	99.87	1,226.90			
67.16	99.87	1,258.35			
67.31	100.38	1,282.37			
67.46	100.88	1,306.46			
67.61	101.38	1,330.63			
67.76	101.87	1,354.88			
67.91	102.35	1,379.21			
68.06	102.83	1,403.62			
68.21	103.30	1,428.10			
68.36	103.76	1,452.64			
68.51	104.22	1,477.27			
68.66	104.67	1,501.96			
68.81	105.11	1,526.72			

**POST DEVEL**

Prepared by Fuller Engineering & Land Surveying, LLC  
HydroCAD® 10.00 s/n 02123 © 2011 HydroCAD Software Solutions LLC

#245 Route 32 Montville, CT  
Type III 24-hr 25-YEAR Rainfall=6.15"

Printed 3/15/2022

Page 26

**Stage-Area-Storage for Reach 1R: DROP MANHOLE**

Elevation (feet)	End-Area (sq-ft)	Storage (cubic-feet)	Elevation (feet)	End-Area (sq-ft)	Storage (cubic-feet)
61.16	0.0	0	68.96	14.7	176
61.31	0.3	4	69.11	14.9	178
61.46	0.6	8	69.26	15.1	181
61.61	0.9	11	69.41	15.2	183
61.76	1.3	15	69.56	15.4	185
61.91	1.6	19	69.71	15.6	187
62.06	1.9	23	69.86	15.8	189
62.21	2.2	26	70.01	15.9	191
62.36	2.5	30	70.16	16.1	193
62.51	2.8	34	70.31	16.3	195
62.66	3.1	38	70.46	16.4	197
62.81	3.5	42	70.61	16.6	200
62.96	3.8	45	70.76	16.8	202
63.11	4.1	49	70.91	17.0	204
63.26	4.4	53	71.06	17.2	206
63.41	4.7	57	71.21	17.3	208
63.56	5.0	60	71.36	17.5	210
63.71	5.4	64	71.51	17.7	212
63.86	5.7	68	71.66	17.9	214
64.01	6.0	72	71.81	18.0	216
64.16	6.3	76	71.96	18.2	218
64.31	6.6	79	72.11	18.4	220
64.46	6.9	83	72.26	18.6	223
64.61	7.2	87	72.41	18.7	225
64.76	7.6	91	72.56	18.9	227
64.91	7.9	95	72.71	19.1	229
65.06	8.2	98	72.86	19.3	231
65.21	8.5	102	73.01	19.4	233
65.36	8.8	106	73.16	19.6	235
65.51	9.1	110			
65.66	9.4	113			
65.81	9.8	117			
65.96	10.1	121			
66.11	10.4	125			
66.26	10.7	129			
66.41	11.0	132			
66.56	11.3	136			
66.71	11.7	140			
66.86	12.0	144			
67.01	12.3	147			
67.16	12.6	151			
67.31	12.8	153			
67.46	12.9	155			
67.61	13.1	158			
67.76	13.3	160			
67.91	13.5	162			
68.06	13.7	164			
68.21	13.8	166			
68.36	14.0	168			
68.51	14.2	170			
68.66	14.3	172			
68.81	14.5	174			

**POST DEVEL**

Prepared by Fuller Engineering & Land Surveying, LLC  
HydroCAD® 10.00 s/n 02123 © 2011 HydroCAD Software Solutions LLC

#245 Route 32 Montville, CT  
Type III 24-hr 25-YEAR Rainfall=6.15"  
Printed 3/15/2022  
Page 27

**Summary for Pond 1P: 60 CONCRETE GALLEY'S**

[93] Warning: Storage range exceeded by 4.26'

Inflow Area = 59,949 sf, 75.44% Impervious, Inflow Depth > 5.14" for 25-YEAR event  
Inflow = 4.52 cfs @ 12.39 hrs, Volume= 25,690 cf  
Outflow = 4.10 cfs @ 12.57 hrs, Volume= 22,025 cf, Atten= 9%, Lag= 10.7 min  
Discarded = 0.28 cfs @ 12.56 hrs, Volume= 14,683 cf  
Primary = 3.82 cfs @ 12.57 hrs, Volume= 7,342 cf

Routing by Stor-Ind method, Time Span= 0.00-24.00 hrs, dt= 0.05 hrs  
Peak Elev= 66.76' @ 12.56 hrs Surf.Area= 2,574 sf Storage= 8,014 cf

Plug-Flow detention time= 160.0 min calculated for 22,025 cf (86% of inflow)  
Center-of-Mass det. time= 99.9 min ( 896.8 - 796.9 )

Volume	Invert	Avail.Storage	Storage Description
#1A	57.33'	2,401 cf	<b>21.10'W x 122.00'L x 5.17'H Field A</b> 13,300 cf Overall - 7,298 cf Embedded = 6,002 cf x 40.0% Voids
#2A	57.83'	5,614 cf	<b>Galley 4x8x4 x 60 Inside #1</b> Inside= 42.0"W x 43.0"H => 12.47 sf x 7.50'L = 93.6 cf Outside= 52.8"W x 48.0"H => 15.20 sf x 8.00'L = 121.6 cf
		8,014 cf	Total Available Storage

Storage Group A created with Chamber Wizard

Device	Routing	Invert	Outlet Devices
#1	Primary	61.50'	<b>8.0" Vert. Orifice/Grate</b> C= 0.600
#2	Discarded	57.33'	<b>4.000 in/hr Exfiltration over Surface area</b> Conductivity to Groundwater Elevation = 0.00'

**Discarded OutFlow** Max=0.28 cfs @ 12.56 hrs HW=66.21' (Free Discharge)  
↳ **2=Exfiltration** ( Controls 0.28 cfs)

**Primary OutFlow** Max=3.49 cfs @ 12.57 hrs HW=66.14' (Free Discharge)  
↳ **1=Orifice/Grate** (Orifice Controls 3.49 cfs @ 9.99 fps)

**POST DEVEL**

Prepared by Fuller Engineering & Land Surveying, LLC  
HydroCAD® 10.00 s/n 02123 © 2011 HydroCAD Software Solutions LLC

#245 Route 32 Montville, CT  
Type III 24-hr 25-YEAR Rainfall=6.15"

Printed 3/15/2022

Page 28

**Pond 1P: 60 CONCRETE GALLEY'S - Chamber Wizard Field A**

**Chamber Model = Galley 4x8x4**

Inside= 42.0"W x 43.0"H => 12.47 sf x 7.50'L = 93.6 cf

Outside= 52.8"W x 48.0"H => 15.20 sf x 8.00'L = 121.6 cf

52.8" Wide + 6.0" Spacing = 58.8" C-C Row Spacing

15 Chambers/Row x 8.00' Long = 120.00' Row Length +12.0" End Stone x 2 = 122.00' Base Length

4 Rows x 52.8" Wide + 6.0" Spacing x 3 + 12.0" Side Stone x 2 = 21.10' Base Width

6.0" Base + 48.0" Chamber Height + 8.0" Cover = 5.17' Field Height

60 Chambers x 93.6 cf = 5,613.7 cf Chamber Storage

60 Chambers x 121.6 cf = 7,298.2 cf Displacement

13,300.0 cf Field - 7,298.2 cf Chambers = 6,001.9 cf Stone x 40.0% Voids = 2,400.7 cf Stone Storage

Stone + Chamber Storage = 8,014.5 cf = 0.184 af

Overall Storage Efficiency = 60.3%

60 Chambers

492.6 cy Field

222.3 cy Stone

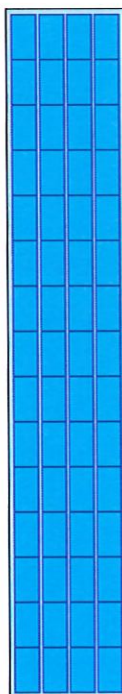

**POST DEVEL**

Prepared by Fuller Engineering & Land Surveying, LLC  
HydroCAD® 10.00 s/n 02123 © 2011 HydroCAD Software Solutions LLC

#245 Route 32 Montville, CT  
Type III 24-hr 25-YEAR Rainfall=6.15"

Printed 3/15/2022  
Page 29

**Pond 1P: 60 CONCRETE GALLEY'S**

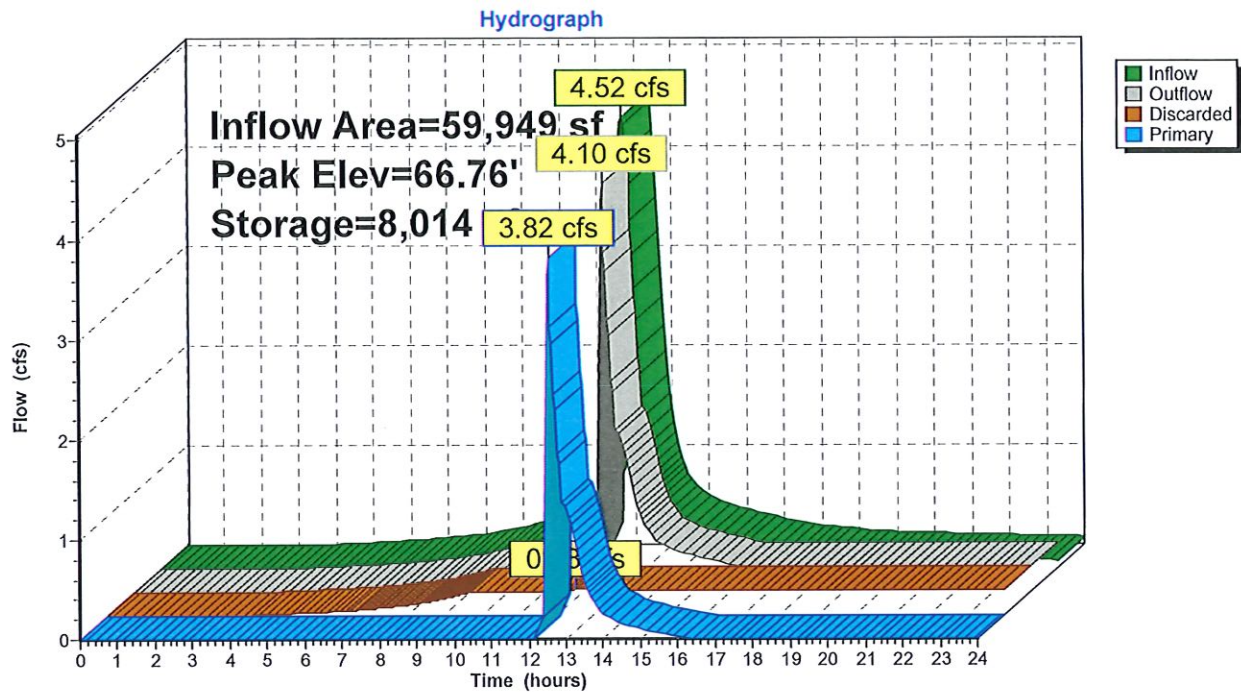

**Pond 1P: 60 CONCRETE GALLEY'S**

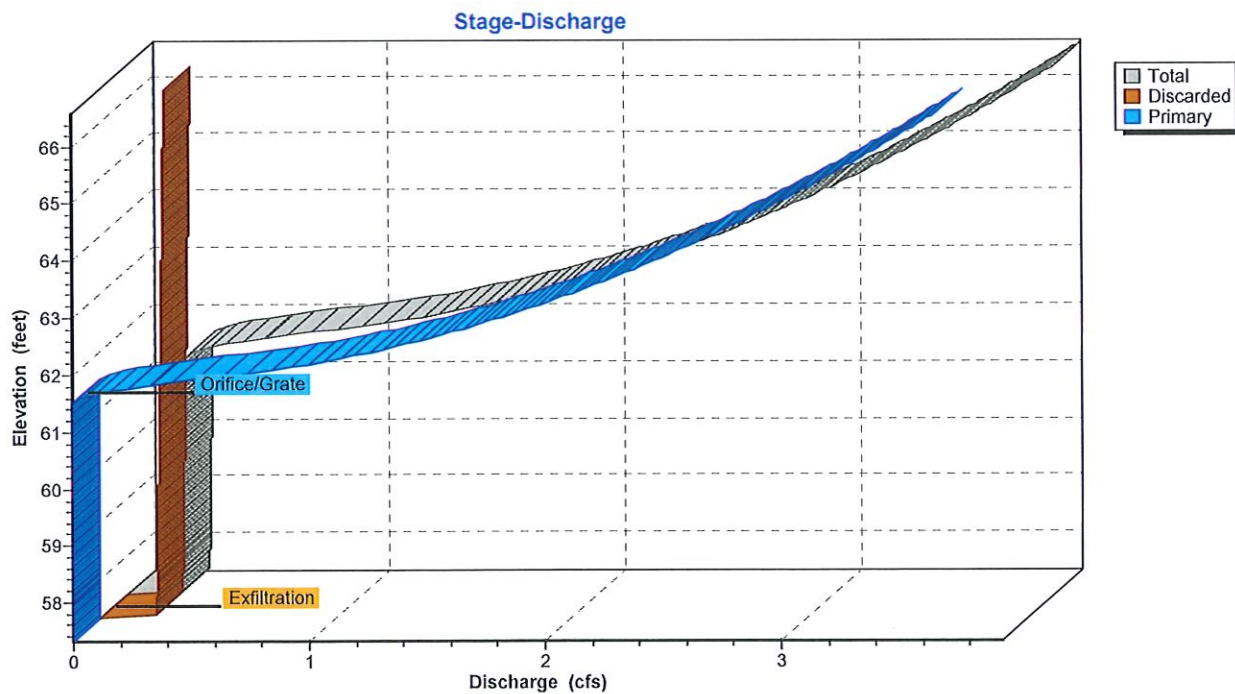

**POST DEVEL**

Prepared by Fuller Engineering & Land Surveying, LLC  
HydroCAD® 10.00 s/n 02123 © 2011 HydroCAD Software Solutions LLC

#245 Route 32 Montville, CT  
Type III 24-hr 25-YEAR Rainfall=6.15"

Printed 3/15/2022

Page 30

**Pond 1P: 60 CONCRETE GALLEY'S**

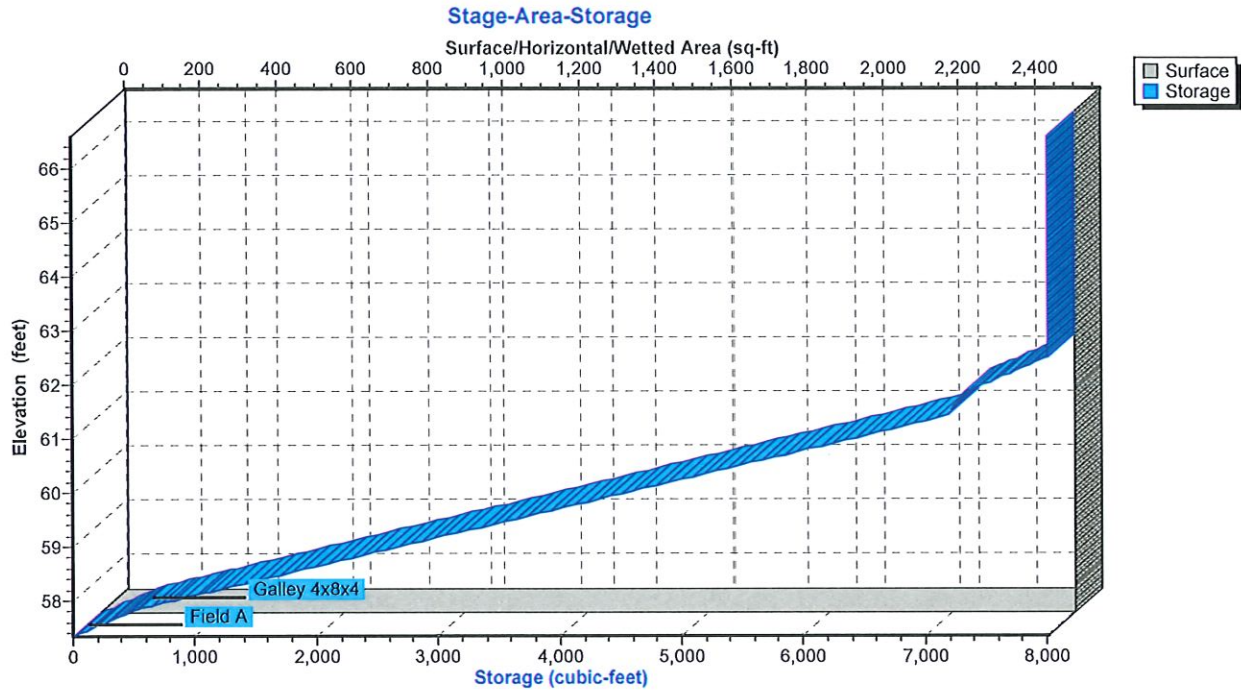



**POST DEVEL**

Prepared by Fuller Engineering & Land Surveying, LLC  
HydroCAD® 10.00 s/n 02123 © 2011 HydroCAD Software Solutions LLC

#245 Route 32 Montville, CT  
Type III 24-hr 25-YEAR Rainfall=6.15"

Printed 3/15/2022

Page 31

**Hydrograph for Pond 1P: 60 CONCRETE GALLEY'S**

Time (hours)	Inflow (cfs)	Storage (cubic-feet)	Elevation (feet)	Outflow (cfs)	Discarded (cfs)	Primary (cfs)
0.00	0.00	0	57.33	0.00	0.00	0.00
0.50	0.00	0	57.33	0.00	0.00	0.00
1.00	0.00	0	57.33	0.00	0.00	0.00
1.50	0.00	0	57.33	0.00	0.00	0.00
2.00	0.00	0	57.33	0.00	0.00	0.00
2.50	0.00	0	57.33	0.00	0.00	0.00
3.00	0.00	0	57.33	0.00	0.00	0.00
3.50	0.00	0	57.33	0.00	0.00	0.00
4.00	0.01	2	57.33	0.01	0.01	0.00
4.50	0.02	4	57.33	0.02	0.02	0.00
5.00	0.03	6	57.34	0.03	0.03	0.00
5.50	0.04	8	57.34	0.03	0.03	0.00
6.00	0.04	10	57.34	0.04	0.04	0.00
6.50	0.06	12	57.34	0.05	0.05	0.00
7.00	0.07	15	57.35	0.07	0.07	0.00
7.50	0.09	20	57.35	0.09	0.09	0.00
8.00	0.11	24	57.35	0.11	0.11	0.00
8.50	0.14	30	57.36	0.13	0.13	0.00
9.00	0.18	38	57.37	0.17	0.17	0.00
9.50	0.22	48	57.38	0.22	0.22	0.00
10.00	0.27	73	57.40	0.24	0.24	0.00
10.50	0.33	184	57.51	0.24	0.24	0.00
11.00	0.43	435	57.75	0.24	0.24	0.00
11.50	0.59	886	58.03	0.24	0.24	0.00
12.00	1.61	2,076	58.66	0.24	0.24	0.00
12.50	4.16	7,769	62.26	1.35	0.26	1.10
13.00	1.37	7,983	62.47	1.60	0.26	1.34
13.50	0.66	7,448	61.95	0.82	0.26	0.57
14.00	0.50	7,313	61.78	0.51	0.26	0.26
14.50	0.41	7,293	61.72	0.42	0.26	0.16
15.00	0.36	7,279	61.68	0.36	0.26	0.11
15.50	0.31	7,264	61.63	0.32	0.26	0.06
16.00	0.26	7,244	61.57	0.27	0.26	0.02
16.50	0.22	7,202	61.44	0.26	0.26	0.00
17.00	0.19	7,113	61.37	0.26	0.26	0.00
17.50	0.17	6,985	61.30	0.25	0.25	0.00
18.00	0.15	6,820	61.21	0.25	0.25	0.00
18.50	0.14	6,620	61.10	0.25	0.25	0.00
19.00	0.13	6,398	60.98	0.25	0.25	0.00
19.50	0.12	6,165	60.85	0.25	0.25	0.00
20.00	0.11	5,922	60.72	0.25	0.25	0.00
20.50	0.11	5,669	60.59	0.25	0.25	0.00
21.00	0.10	5,407	60.45	0.25	0.25	0.00
21.50	0.10	5,137	60.30	0.25	0.25	0.00
22.00	0.09	4,861	60.15	0.25	0.25	0.00
22.50	0.09	4,576	60.00	0.25	0.25	0.00
23.00	0.08	4,285	59.84	0.25	0.25	0.00
23.50	0.08	3,986	59.68	0.25	0.25	0.00
24.00	0.08	3,680	59.52	0.25	0.25	0.00

**POST DEVEL**

Prepared by Fuller Engineering & Land Surveying, LLC

Printed 3/15/2022

HydroCAD® 10.00 s/n 02123 © 2011 HydroCAD Software Solutions LLC

Page 32

**Stage-Discharge for Pond IP: 60 CONCRETE GALLEY'S**

Elevation (feet)	Discharge (cfs)	Discarded (cfs)	Primary (cfs)	Elevation (feet)	Discharge (cfs)	Discarded (cfs)	Primary (cfs)
57.33	0.00	0.00	0.00	62.53	1.66	0.26	1.40
57.43	0.24	0.24	0.00	62.63	1.76	0.26	1.50
57.53	0.24	0.24	0.00	62.73	1.85	0.26	1.59
57.63	0.24	0.24	0.00	62.83	1.94	0.26	1.68
57.73	0.24	0.24	0.00	62.93	2.02	0.26	1.76
57.83	0.24	0.24	0.00	63.03	2.10	0.26	1.84
57.93	0.24	0.24	0.00	63.13	2.18	0.26	1.91
58.03	0.24	0.24	0.00	63.23	2.25	0.26	1.99
58.13	0.24	0.24	0.00	63.33	2.32	0.26	2.06
58.23	0.24	0.24	0.00	63.43	2.39	0.26	2.12
58.33	0.24	0.24	0.00	63.53	2.45	0.26	2.19
58.43	0.24	0.24	0.00	63.63	2.52	0.26	2.25
58.53	0.24	0.24	0.00	63.73	2.58	0.26	2.31
58.63	0.24	0.24	0.00	63.83	2.64	0.27	2.37
58.73	0.24	0.24	0.00	63.93	2.70	0.27	2.43
58.83	0.24	0.24	0.00	64.03	2.76	0.27	2.49
58.93	0.25	0.25	0.00	64.13	2.81	0.27	2.55
59.03	0.25	0.25	0.00	64.23	2.87	0.27	2.60
59.13	0.25	0.25	0.00	64.33	2.92	0.27	2.66
59.23	0.25	0.25	0.00	64.43	2.98	0.27	2.71
59.33	0.25	0.25	0.00	64.53	3.03	0.27	2.76
59.43	0.25	0.25	0.00	64.63	3.08	0.27	2.81
59.53	0.25	0.25	0.00	64.73	3.13	0.27	2.86
59.63	0.25	0.25	0.00	64.83	3.18	0.27	2.91
59.73	0.25	0.25	0.00	64.93	3.23	0.27	2.96
59.83	0.25	0.25	0.00	65.03	3.28	0.27	3.01
59.93	0.25	0.25	0.00	65.13	3.32	0.27	3.05
60.03	0.25	0.25	0.00	65.23	3.37	0.27	3.10
60.13	0.25	0.25	0.00	65.33	3.41	0.27	3.14
60.23	0.25	0.25	0.00	65.43	3.46	0.27	3.19
60.33	0.25	0.25	0.00	65.53	3.50	0.27	3.23
60.43	0.25	0.25	0.00	65.63	3.55	0.27	3.27
60.53	0.25	0.25	0.00	65.73	3.59	0.27	3.32
60.63	0.25	0.25	0.00	65.83	3.63	0.27	3.36
60.73	0.25	0.25	0.00	65.93	3.68	0.27	3.40
60.83	0.25	0.25	0.00	66.03	3.72	0.27	3.44
60.93	0.25	0.25	0.00	66.13	3.76	0.27	3.48
61.03	0.25	0.25	0.00	66.23	3.80	0.28	3.52
61.13	0.25	0.25	0.00	66.33	3.84	0.28	3.56
61.23	0.25	0.25	0.00	66.43	3.88	0.28	3.60
61.33	0.25	0.25	0.00	66.53	3.92	0.28	3.64
61.43	0.26	0.26	0.00				
61.53	0.26	0.26	0.00				
61.63	0.32	0.26	0.06				
61.73	0.43	0.26	0.17				
61.83	0.59	0.26	0.34				
61.93	0.79	0.26	0.53				
62.03	1.00	0.26	0.74				
62.13	1.18	0.26	0.92				
62.23	1.32	0.26	1.06				
62.33	1.44	0.26	1.18				
62.43	1.56	0.26	1.30				

**POST DEVEL**

Prepared by Fuller Engineering & Land Surveying, LLC

Printed 3/15/2022

HydroCAD® 10.00 s/n 02123 © 2011 HydroCAD Software Solutions LLC

Page 33

**Stage-Area-Storage for Pond 1P: 60 CONCRETE GALLEY'S**

Elevation (feet)	Surface (sq-ft)	Storage (cubic-feet)	Elevation (feet)	Surface (sq-ft)	Storage (cubic-feet)
57.33	2,574	0	62.53	2,574	8,014
57.43	2,574	103	62.63	2,574	8,014
57.53	2,574	206	62.73	2,574	8,014
57.63	2,574	309	62.83	2,574	8,014
57.73	2,574	412	62.93	2,574	8,014
57.83	2,574	515	63.03	2,574	8,014
57.93	2,574	697	63.13	2,574	8,014
58.03	2,574	880	63.23	2,574	8,014
58.13	2,574	1,066	63.33	2,574	8,014
58.23	2,574	1,255	63.43	2,574	8,014
58.33	2,574	1,444	63.53	2,574	8,014
58.43	2,574	1,633	63.63	2,574	8,014
58.53	2,574	1,822	63.73	2,574	8,014
58.63	2,574	2,010	63.83	2,574	8,014
58.73	2,574	2,198	63.93	2,574	8,014
58.83	2,574	2,387	64.03	2,574	8,014
58.93	2,574	2,575	64.13	2,574	8,014
59.03	2,574	2,763	64.23	2,574	8,014
59.13	2,574	2,950	64.33	2,574	8,014
59.23	2,574	3,138	64.43	2,574	8,014
59.33	2,574	3,326	64.53	2,574	8,014
59.43	2,574	3,513	64.63	2,574	8,014
59.53	2,574	3,700	64.73	2,574	8,014
59.63	2,574	3,887	64.83	2,574	8,014
59.73	2,574	4,074	64.93	2,574	8,014
59.83	2,574	4,261	65.03	2,574	8,014
59.93	2,574	4,448	65.13	2,574	8,014
60.03	2,574	4,634	65.23	2,574	8,014
60.13	2,574	4,820	65.33	2,574	8,014
60.23	2,574	5,007	65.43	2,574	8,014
60.33	2,574	5,193	65.53	2,574	8,014
60.43	2,574	5,379	65.63	2,574	8,014
60.53	2,574	5,564	65.73	2,574	8,014
60.63	2,574	5,750	65.83	2,574	8,014
60.73	2,574	5,935	65.93	2,574	8,014
60.83	2,574	6,121	66.03	2,574	8,014
60.93	2,574	6,306	66.13	2,574	8,014
61.03	2,574	6,491	66.23	2,574	8,014
61.13	2,574	6,676	66.33	2,574	8,014
61.23	2,574	6,861	66.43	2,574	8,014
61.33	2,574	7,046	66.53	2,574	8,014
61.43	2,574	7,200			
61.53	2,574	7,232			
61.63	2,574	7,264			
61.73	2,574	7,296			
61.83	2,574	7,328			
61.93	2,574	7,431			
62.03	2,574	7,534			
62.13	2,574	7,637			
62.23	2,574	7,740			
62.33	2,574	7,843			
62.43	2,574	7,946			

**POST DEVEL**

Prepared by Fuller Engineering & Land Surveying, LLC  
HydroCAD® 10.00 s/n 02123 © 2011 HydroCAD Software Solutions LLC

#245 Route 32 Montville, CT  
Type III 24-hr 25-YEAR Rainfall=6.15"

Printed 3/15/2022

Page 34

**Summary for Pond 2P: Level Spreader**

- [93] Warning: Storage range exceeded by 0.88'
- [88] Warning: Qout>Qin may require Finer Routing>1
- [85] Warning: Oscillations may require Finer Routing>1
- [62] Hint: Exceeded Reach 1R OUTLET depth by 1.53' @ 12.60 hrs

Inflow Area = 59,949 sf, 75.44% Impervious, Inflow Depth = 1.47" for 25-YEAR event  
 Inflow = 3.82 cfs @ 12.57 hrs, Volume= 7,342 cf  
 Outflow = 3.87 cfs @ 12.57 hrs, Volume= 7,145 cf, Atten= 0%, Lag= 0.3 min  
 Discarded = 0.00 cfs @ 0.00 hrs, Volume= 0 cf  
 Primary = 3.87 cfs @ 12.57 hrs, Volume= 7,145 cf

Routing by Stor-Ind method, Time Span= 0.00-24.00 hrs, dt= 0.05 hrs  
 Peak Elev= 53.55' @ 12.55 hrs Surf.Area= 147 sf Storage= 209 cf

Plug-Flow detention time= 5.1 min calculated for 7,130 cf (97% of inflow)  
 Center-of-Mass det. time= 1.4 min ( 790.4 - 789.0 )

Volume	Invert	Avail.Storage	Storage Description
#1A	49.50'	161 cf	<b>3.50'W x 42.00'L x 3.17'H Field A</b> 465 cf Overall - 64 cf Embedded = 401 cf x 40.0% Voids
#2A	50.00'	48 cf	<b>ADS N-12 15 x 2 Inside #1</b> Inside= 14.8"W x 14.8"H => 1.20 sf x 20.00'L = 24.0 cf Outside= 18.0"W x 18.0"H => 1.60 sf x 20.00'L = 31.9 cf
		209 cf	Total Available Storage

Storage Group A created with Chamber Wizard

Device	Routing	Invert	Outlet Devices
#1	Discarded	49.50'	<b>3.500 in/hr Exfiltration over Surface area</b> Conductivity to Groundwater Elevation = 49.50'
#2	Primary	53.50'	<b>84.0" x 504.0" Horiz. Orifice/Grate</b> C= 0.600 Limited to weir flow at low heads

**Discarded OutFlow** Max=0.00 cfs @ 0.00 hrs HW=49.50' (Free Discharge)  
 ↑1=Exfiltration ( Controls 0.00 cfs)

**Primary OutFlow** Max=3.29 cfs @ 12.57 hrs HW=53.55' (Free Discharge)  
 ↑2=Orifice/Grate (Weir Controls 3.29 cfs @ 0.71 fps)

**POST DEVEL**

Prepared by Fuller Engineering & Land Surveying, LLC  
HydroCAD® 10.00 s/n 02123 © 2011 HydroCAD Software Solutions LLC

#245 Route 32 Montville, CT  
Type III 24-hr 25-YEAR Rainfall=6.15"

Printed 3/15/2022

Page 35

**Pond 2P: Level Spreader - Chamber Wizard Field A**

**Chamber Model = ADS N-12 15**

Inside= 14.8"W x 14.8"H => 1.20 sf x 20.00'L = 24.0 cf

Outside= 18.0"W x 18.0"H => 1.60 sf x 20.00'L = 31.9 cf

18.0" Wide + 6.0" Spacing = 24.0" C-C Row Spacing

2 Chambers/Row x 20.00' Long = 40.00' Row Length +12.0" End Stone x 2 = 42.00' Base Length

1 Rows x 18.0" Wide + 12.0" Side Stone x 2 = 3.50' Base Width

6.0" Base + 18.0" Chamber Height + 14.0" Cover = 3.17' Field Height

2 Chambers x 24.0 cf = 48.0 cf Chamber Storage

2 Chambers x 31.9 cf = 63.8 cf Displacement

465.3 cf Field - 63.8 cf Chambers = 401.5 cf Stone x 40.0% Voids = 160.6 cf Stone Storage

Stone + Chamber Storage = 208.6 cf = 0.005 af

Overall Storage Efficiency = 44.8%

2 Chambers

17.2 cy Field

14.9 cy Stone



**POST DEVEL**

Prepared by Fuller Engineering & Land Surveying, LLC  
HydroCAD® 10.00 s/n 02123 © 2011 HydroCAD Software Solutions LLC

#245 Route 32 Montville, CT  
Type III 24-hr 25-YEAR Rainfall=6.15"

Printed 3/15/2022

Page 36

**Pond 2P: Level Spreader**

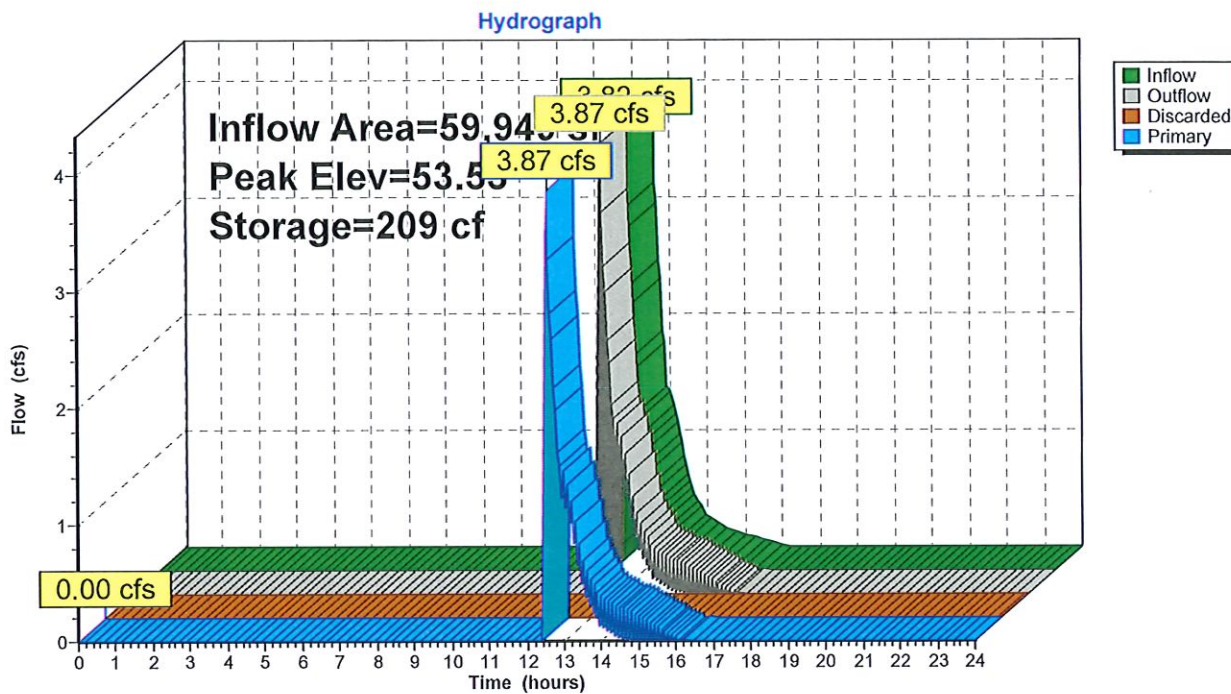

**Pond 2P: Level Spreader**

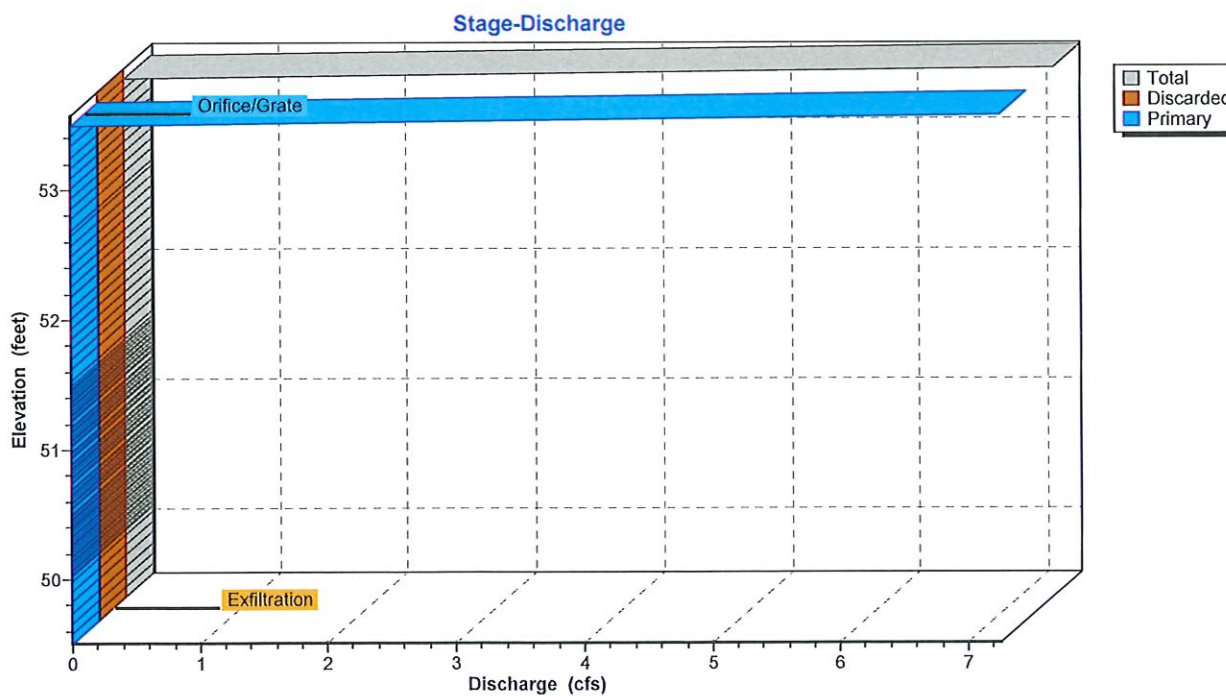

**POST DEVEL**

Prepared by Fuller Engineering & Land Surveying, LLC  
HydroCAD® 10.00 s/n 02123 © 2011 HydroCAD Software Solutions LLC

#245 Route 32 Montville, CT  
Type III 24-hr 25-YEAR Rainfall=6.15"

Printed 3/15/2022

Page 37

**Pond 2P: Level Spreader**

**Stage-Area-Storage**

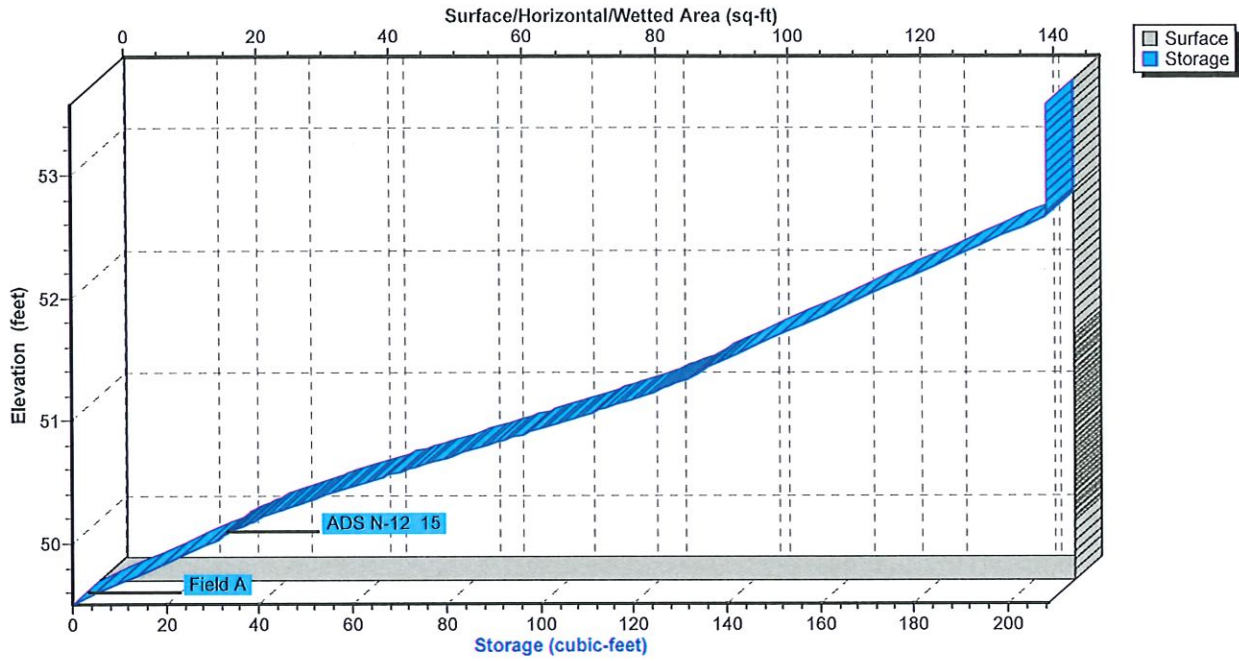

**POST DEVEL**

Prepared by Fuller Engineering & Land Surveying, LLC

Printed 3/15/2022

HydroCAD® 10.00 s/n 02123 © 2011 HydroCAD Software Solutions LLC

Page 38

**Hydrograph for Pond 2P: Level Spreader**

Time (hours)	Inflow (cfs)	Storage (cubic-feet)	Elevation (feet)	Outflow (cfs)	Discarded (cfs)	Primary (cfs)
0.00	0.00	0	49.50	0.00	0.00	0.00
0.50	0.00	0	49.50	0.00	0.00	0.00
1.00	0.00	0	49.50	0.00	0.00	0.00
1.50	0.00	0	49.50	0.00	0.00	0.00
2.00	0.00	0	49.50	0.00	0.00	0.00
2.50	0.00	0	49.50	0.00	0.00	0.00
3.00	0.00	0	49.50	0.00	0.00	0.00
3.50	0.00	0	49.50	0.00	0.00	0.00
4.00	0.00	0	49.50	0.00	0.00	0.00
4.50	0.00	0	49.50	0.00	0.00	0.00
5.00	0.00	0	49.50	0.00	0.00	0.00
5.50	0.00	0	49.50	0.00	0.00	0.00
6.00	0.00	0	49.50	0.00	0.00	0.00
6.50	0.00	0	49.50	0.00	0.00	0.00
7.00	0.00	0	49.50	0.00	0.00	0.00
7.50	0.00	0	49.50	0.00	0.00	0.00
8.00	0.00	0	49.50	0.00	0.00	0.00
8.50	0.00	0	49.50	0.00	0.00	0.00
9.00	0.00	0	49.50	0.00	0.00	0.00
9.50	0.00	0	49.50	0.00	0.00	0.00
10.00	0.00	0	49.50	0.00	0.00	0.00
10.50	0.00	0	49.50	0.00	0.00	0.00
11.00	0.00	0	49.50	0.00	0.00	0.00
11.50	0.00	0	49.50	0.00	0.00	0.00
12.00	0.00	0	49.50	0.00	0.00	0.00
12.50	1.09	98	50.91	0.00	0.00	0.00
13.00	1.34	209	53.52	1.47	0.00	1.47
13.50	0.57	209	53.51	0.70	0.00	0.70
14.00	0.26	209	53.51	0.39	0.00	0.39
14.50	0.17	209	53.50	0.30	0.00	0.30
15.00	0.11	209	53.50	0.22	0.00	0.22
15.50	0.06	209	53.50	0.13	0.00	0.13
16.00	0.02	209	53.50	0.04	0.00	0.04
16.50	0.00	209	53.50	0.00	0.00	0.00
17.00	0.00	209	53.50	0.00	0.00	0.00
17.50	0.00	209	53.50	0.00	0.00	0.00
18.00	0.00	209	53.50	0.00	0.00	0.00
18.50	0.00	209	53.50	0.00	0.00	0.00
19.00	0.00	209	53.50	0.00	0.00	0.00
19.50	0.00	209	53.50	0.00	0.00	0.00
20.00	0.00	209	53.50	0.00	0.00	0.00
20.50	0.00	209	53.50	0.00	0.00	0.00
21.00	0.00	209	53.50	0.00	0.00	0.00
21.50	0.00	209	53.50	0.00	0.00	0.00
22.00	0.00	209	53.50	0.00	0.00	0.00
22.50	0.00	209	53.50	0.00	0.00	0.00
23.00	0.00	209	53.50	0.00	0.00	0.00
23.50	0.00	209	53.50	0.00	0.00	0.00
24.00	0.00	209	53.50	0.00	0.00	0.00



**POST DEVEL**

Prepared by Fuller Engineering & Land Surveying, LLC

Printed 3/15/2022

HydroCAD® 10.00 s/n 02123 © 2011 HydroCAD Software Solutions LLC

Page 39

**Stage-Discharge for Pond 2P: Level Spreader**

Elevation (feet)	Discharge (cfs)	Discarded (cfs)	Primary (cfs)	Elevation (feet)	Discharge (cfs)	Discarded (cfs)	Primary (cfs)
49.50	0.00	0.00	0.00	52.10	0.00	0.00	0.00
49.55	0.00	0.00	0.00	52.15	0.00	0.00	0.00
49.60	0.00	0.00	0.00	52.20	0.00	0.00	0.00
49.65	0.00	0.00	0.00	52.25	0.00	0.00	0.00
49.70	0.00	0.00	0.00	52.30	0.00	0.00	0.00
49.75	0.00	0.00	0.00	52.35	0.00	0.00	0.00
49.80	0.00	0.00	0.00	52.40	0.00	0.00	0.00
49.85	0.00	0.00	0.00	52.45	0.00	0.00	0.00
49.90	0.00	0.00	0.00	52.50	0.00	0.00	0.00
49.95	0.00	0.00	0.00	52.55	0.00	0.00	0.00
50.00	0.00	0.00	0.00	52.60	0.00	0.00	0.00
50.05	0.00	0.00	0.00	52.65	0.00	0.00	0.00
50.10	0.00	0.00	0.00	52.70	0.00	0.00	0.00
50.15	0.00	0.00	0.00	52.75	0.00	0.00	0.00
50.20	0.00	0.00	0.00	52.80	0.00	0.00	0.00
50.25	0.00	0.00	0.00	52.85	0.00	0.00	0.00
50.30	0.00	0.00	0.00	52.90	0.00	0.00	0.00
50.35	0.00	0.00	0.00	52.95	0.00	0.00	0.00
50.40	0.00	0.00	0.00	53.00	0.00	0.00	0.00
50.45	0.00	0.00	0.00	53.05	0.00	0.00	0.00
50.50	0.00	0.00	0.00	53.10	0.00	0.00	0.00
50.55	0.00	0.00	0.00	53.15	0.00	0.00	0.00
50.60	0.00	0.00	0.00	53.20	0.00	0.00	0.00
50.65	0.00	0.00	0.00	53.25	0.00	0.00	0.00
50.70	0.00	0.00	0.00	53.30	0.00	0.00	0.00
50.75	0.00	0.00	0.00	53.35	0.00	0.00	0.00
50.80	0.00	0.00	0.00	53.40	0.00	0.00	0.00
50.85	0.00	0.00	0.00	53.45	0.00	0.00	0.00
50.90	0.00	0.00	0.00	53.50	0.00	0.00	0.00
50.95	0.00	0.00	0.00	53.55	3.58	0.00	3.58
51.00	0.00	0.00	0.00				
51.05	0.00	0.00	0.00				
51.10	0.00	0.00	0.00				
51.15	0.00	0.00	0.00				
51.20	0.00	0.00	0.00				
51.25	0.00	0.00	0.00				
51.30	0.00	0.00	0.00				
51.35	0.00	0.00	0.00				
51.40	0.00	0.00	0.00				
51.45	0.00	0.00	0.00				
51.50	0.00	0.00	0.00				
51.55	0.00	0.00	0.00				
51.60	0.00	0.00	0.00				
51.65	0.00	0.00	0.00				
51.70	0.00	0.00	0.00				
51.75	0.00	0.00	0.00				
51.80	0.00	0.00	0.00				
51.85	0.00	0.00	0.00				
51.90	0.00	0.00	0.00				
51.95	0.00	0.00	0.00				
52.00	0.00	0.00	0.00				
52.05	0.00	0.00	0.00				

**POST DEVEL**

Prepared by Fuller Engineering & Land Surveying, LLC

Printed 3/15/2022

HydroCAD® 10.00 s/n 02123 © 2011 HydroCAD Software Solutions LLC

Page 40

**Stage-Area-Storage for Pond 2P: Level Spreader**

Elevation (feet)	Surface (sq-ft)	Storage (cubic-feet)	Elevation (feet)	Surface (sq-ft)	Storage (cubic-feet)
49.50	147	0	52.10	147	175
49.55	147	3	52.15	147	178
49.60	147	6	52.20	147	181
49.65	147	9	52.25	147	184
49.70	147	12	52.30	147	187
49.75	147	15	52.35	147	190
49.80	147	18	52.40	147	193
49.85	147	21	52.45	147	196
49.90	147	24	52.50	147	199
49.95	147	26	52.55	147	202
50.00	147	29	52.60	147	205
50.05	147	32	52.65	147	208
50.10	147	35	52.70	147	209
50.15	147	37	52.75	147	209
50.20	147	40	52.80	147	209
50.25	147	44	52.85	147	209
50.30	147	47	52.90	147	209
50.35	147	51	52.95	147	209
50.40	147	55	53.00	147	209
50.45	147	59	53.05	147	209
50.50	147	63	53.10	147	209
50.55	147	68	53.15	147	209
50.60	147	72	53.20	147	209
50.65	147	76	53.25	147	209
50.70	147	80	53.30	147	209
50.75	147	85	53.35	147	209
50.80	147	89	53.40	147	209
50.85	147	93	53.45	147	209
50.90	147	98	53.50	147	209
50.95	147	102	53.55	147	209
51.00	147	106			
51.05	147	110			
51.10	147	114			
51.15	147	118			
51.20	147	122			
51.25	147	126			
51.30	147	129			
51.35	147	132			
51.40	147	135			
51.45	147	137			
51.50	147	140			
51.55	147	143			
51.60	147	146			
51.65	147	149			
51.70	147	152			
51.75	147	155			
51.80	147	158			
51.85	147	161			
51.90	147	164			
51.95	147	166			
52.00	147	169			
52.05	147	172			

**POST DEVEL**

Prepared by Fuller Engineering & Land Surveying, LLC  
HydroCAD® 10.00 s/n 02123 © 2011 HydroCAD Software Solutions LLC

#245 Route 32 Montville, CT  
Type III 24-hr 25-YEAR Rainfall=6.15"

Printed 3/15/2022

Page 41

**Summary for Link 1L: POC "A" LOW POINT AT S.E. END OF PARCEL**

Inflow Area = 79,607 sf, 56.81% Impervious, Inflow Depth > 1.68" for 25-YEAR event  
Inflow = 4.52 cfs @ 12.57 hrs, Volume= 11,149 cf  
Primary = 4.52 cfs @ 12.57 hrs, Volume= 11,149 cf, Atten= 0%, Lag= 0.0 min

Primary outflow = Inflow, Time Span= 0.00-24.00 hrs, dt= 0.05 hrs

**Link 1L: POC "A" LOW POINT AT S.E. END OF PARCEL**

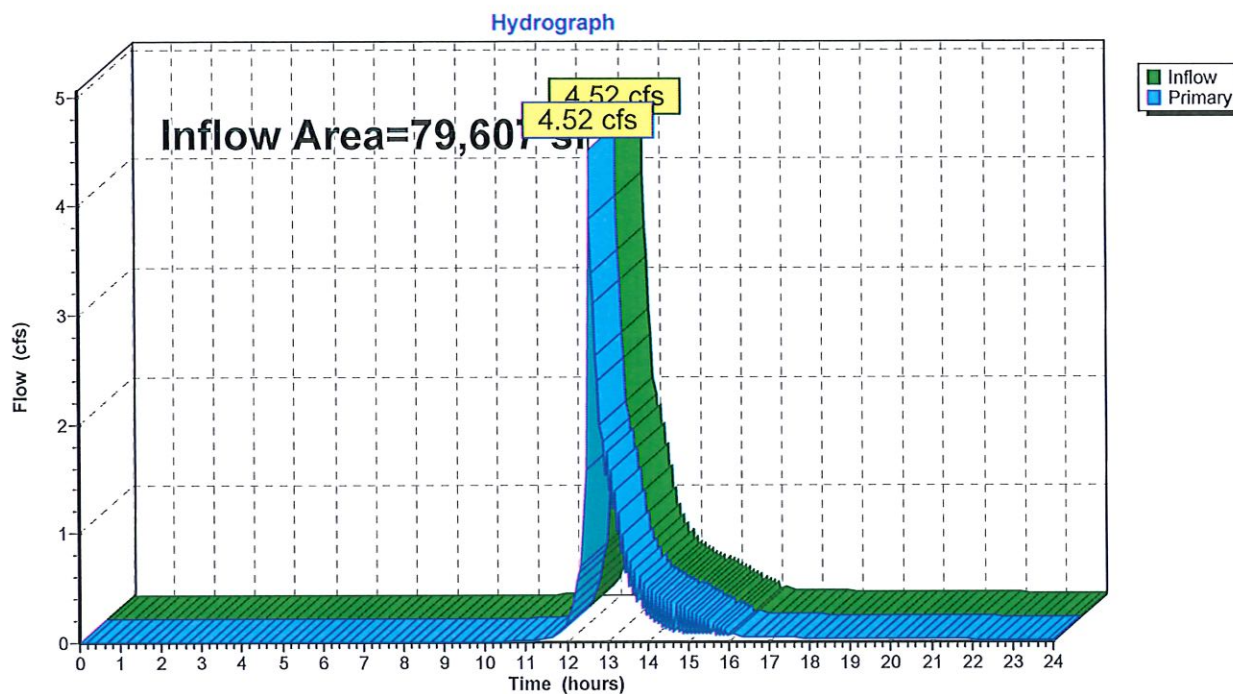

**POST DEVEL**

Prepared by Fuller Engineering & Land Surveying, LLC

Printed 3/15/2022

HydroCAD® 10.00 s/n 02123 © 2011 HydroCAD Software Solutions LLC

Page 42

**Hydrograph for Link 1L: POC "A" LOW POINT AT S.E. END OF PARCEL**

Time (hours)	Inflow (cfs)	Elevation (feet)	Primary (cfs)	Time (hours)	Inflow (cfs)	Elevation (feet)	Primary (cfs)
0.00	0.00	0.00	0.00	13.00	1.74	0.00	1.74
0.25	0.00	0.00	0.00	13.25	1.02	0.00	1.02
0.50	0.00	0.00	0.00	13.50	0.84	0.00	0.84
0.75	0.00	0.00	0.00	13.75	0.36	0.00	0.36
1.00	0.00	0.00	0.00	14.00	0.50	0.00	0.50
1.25	0.00	0.00	0.00	14.25	0.17	0.00	0.17
1.50	0.00	0.00	0.00	14.50	0.39	0.00	0.39
1.75	0.00	0.00	0.00	14.75	0.09	0.00	0.09
2.00	0.00	0.00	0.00	15.00	0.30	0.00	0.30
2.25	0.00	0.00	0.00	15.25	0.08	0.00	0.08
2.50	0.00	0.00	0.00	15.50	0.20	0.00	0.20
2.75	0.00	0.00	0.00	15.75	0.07	0.00	0.07
3.00	0.00	0.00	0.00	16.00	0.10	0.00	0.10
3.25	0.00	0.00	0.00	16.25	0.06	0.00	0.06
3.50	0.00	0.00	0.00	16.50	0.05	0.00	0.05
3.75	0.00	0.00	0.00	16.75	0.05	0.00	0.05
4.00	0.00	0.00	0.00	17.00	0.05	0.00	0.05
4.25	0.00	0.00	0.00	17.25	0.04	0.00	0.04
4.50	0.00	0.00	0.00	17.50	0.04	0.00	0.04
4.75	0.00	0.00	0.00	17.75	0.04	0.00	0.04
5.00	0.00	0.00	0.00	18.00	0.04	0.00	0.04
5.25	0.00	0.00	0.00	18.25	0.03	0.00	0.03
5.50	0.00	0.00	0.00	18.50	0.03	0.00	0.03
5.75	0.00	0.00	0.00	18.75	0.03	0.00	0.03
6.00	0.00	0.00	0.00	19.00	0.03	0.00	0.03
6.25	0.00	0.00	0.00	19.25	0.03	0.00	0.03
6.50	0.00	0.00	0.00	19.50	0.03	0.00	0.03
6.75	0.00	0.00	0.00	19.75	0.03	0.00	0.03
7.00	0.00	0.00	0.00	20.00	0.03	0.00	0.03
7.25	0.00	0.00	0.00	20.25	0.03	0.00	0.03
7.50	0.00	0.00	0.00	20.50	0.03	0.00	0.03
7.75	0.00	0.00	0.00	20.75	0.03	0.00	0.03
8.00	0.00	0.00	0.00	21.00	0.03	0.00	0.03
8.25	0.00	0.00	0.00	21.25	0.02	0.00	0.02
8.50	0.00	0.00	0.00	21.50	0.02	0.00	0.02
8.75	0.00	0.00	0.00	21.75	0.02	0.00	0.02
9.00	0.00	0.00	0.00	22.00	0.02	0.00	0.02
9.25	0.00	0.00	0.00	22.25	0.02	0.00	0.02
9.50	0.00	0.00	0.00	22.50	0.02	0.00	0.02
9.75	0.00	0.00	0.00	22.75	0.02	0.00	0.02
10.00	0.00	0.00	0.00	23.00	0.02	0.00	0.02
10.25	0.00	0.00	0.00	23.25	0.02	0.00	0.02
10.50	0.01	0.00	0.01	23.50	0.02	0.00	0.02
10.75	0.01	0.00	0.01	23.75	0.02	0.00	0.02
11.00	0.02	0.00	0.02	24.00	0.02	0.00	0.02
11.25	0.02	0.00	0.02				
11.50	0.04	0.00	0.04				
11.75	0.06	0.00	0.06				
12.00	0.17	0.00	0.17				
12.25	0.55	0.00	0.55				
12.50	0.70	0.00	0.70				
12.75	2.63	0.00	2.63				

**APPENDIX "M"**

**HYDROCAD – OTHER STORM FREQUENCY SUMMARIES  
2, 5, 10, & 50 YEAR STORMS**

**PRE DEVEL**

Prepared by Fuller Engineering & Land Surveying, LLC  
HydroCAD® 10.00 s/n 02123 © 2011 HydroCAD Software Solutions LLC

Type III 24-hr 2-YEAR Rainfall=3.46"

Printed 3/15/2022

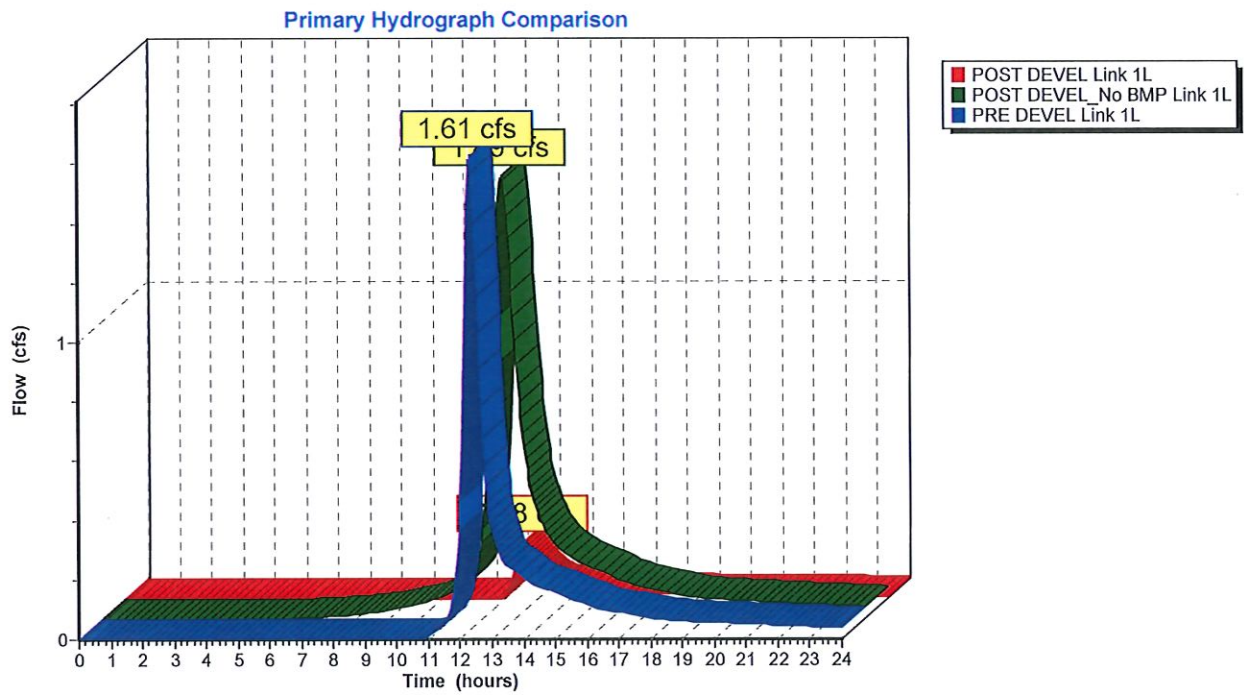

**POST DEVEL**

Prepared by Fuller Engineering & Land Surveying, LLC  
HydroCAD® 10.00 s/n 02123 © 2011 HydroCAD Software Solutions LLC

Type III 24-hr 5-YEAR Rainfall=4.36"

Printed 3/15/2022

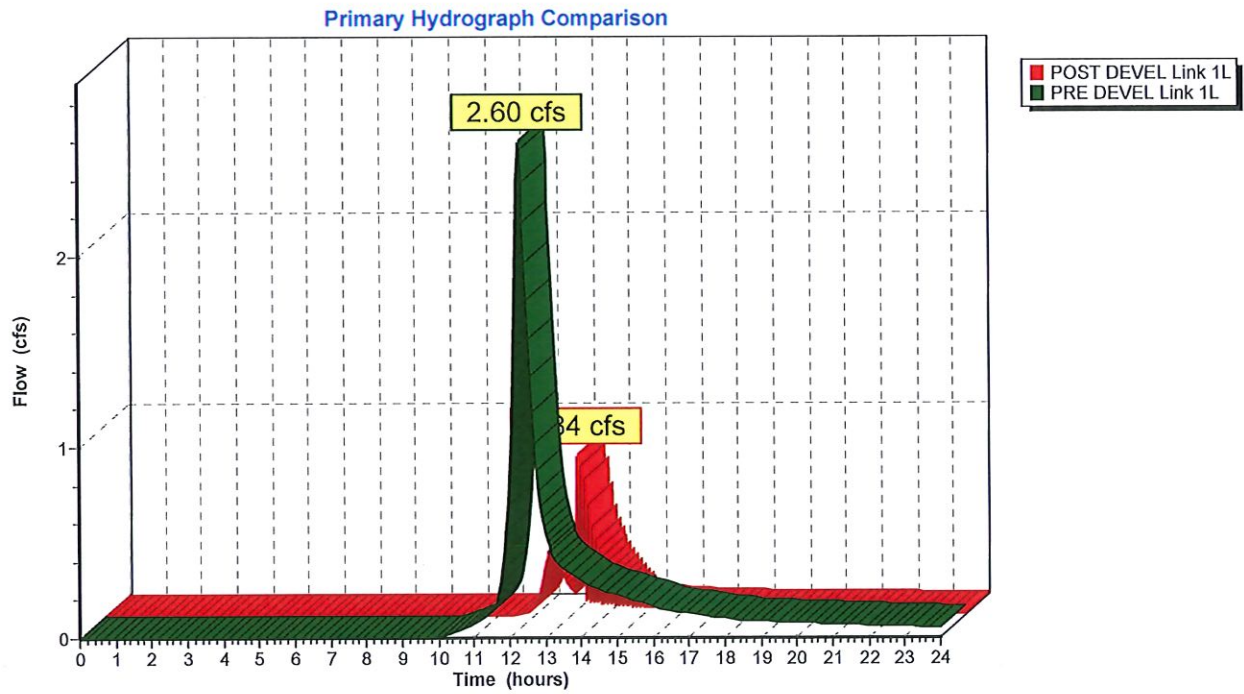

**PRE DEVEL**

Prepared by Fuller Engineering & Land Surveying, LLC  
HydroCAD® 10.00 s/n 02123 © 2011 HydroCAD Software Solutions LLC

Type III 24-hr 10-YEAR Rainfall=5.12"

Printed 3/15/2022

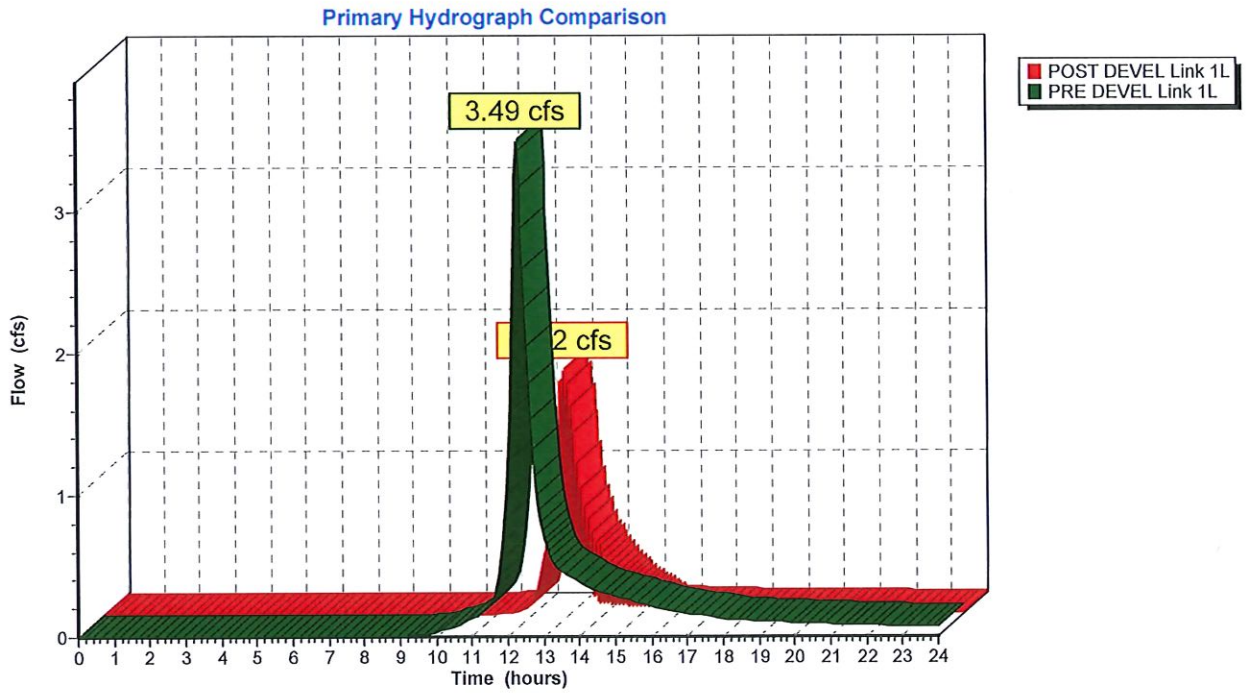



**POST DEVEL**

Prepared by Fuller Engineering & Land Surveying, LLC  
HydroCAD® 10.00 s/n 02123 © 2011 HydroCAD Software Solutions LLC

Type III 24-hr 50-YEAR Rainfall=6.93"

Printed 3/15/2022

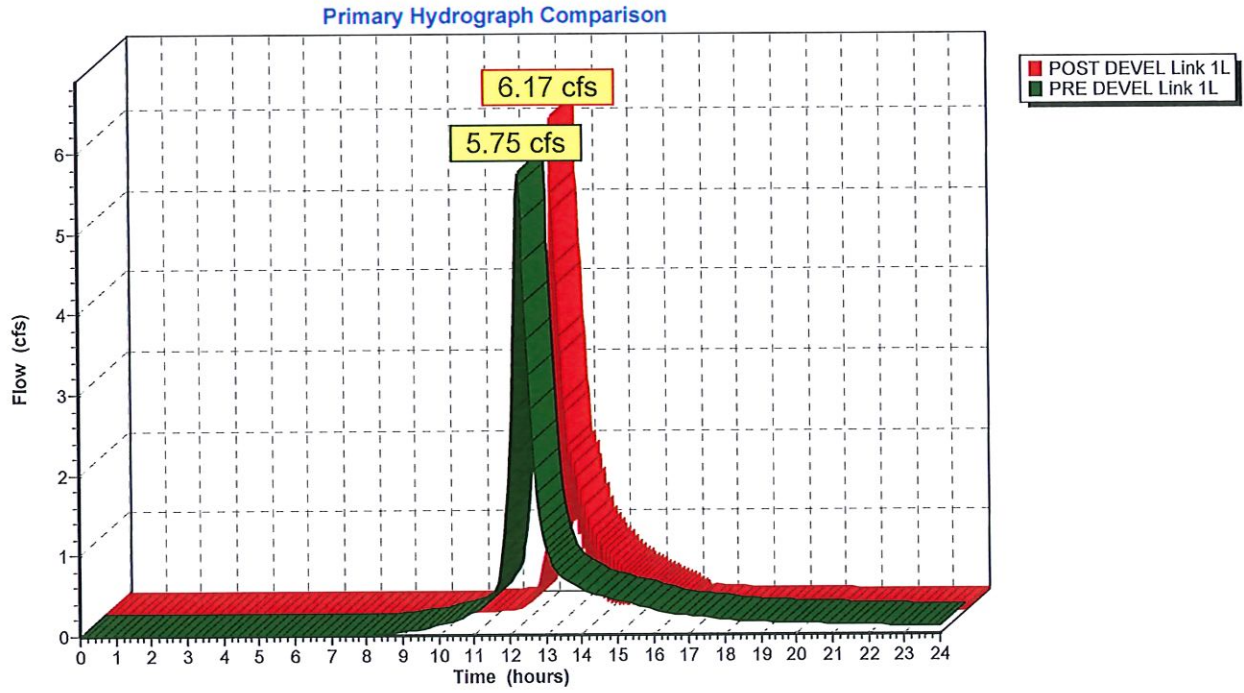

**APPENDIX "O"**  
**OPERATIONS AND MAINTENANCE PLAN**

**Appendix O**  
**Operations and Maintenance Plan**  
*#245 Norwich New London Tpke. Route 32 Montville, CT*  
*March 8, 2022*

Scope:

The purpose of the Operations and Maintenance Plan is to ensure that the existing and proposed stormwater components installed at #245 Route 32, Norwich New London Turnpike Montville, CT are maintained in operational condition throughout the life of the project. The service procedures associated with this plan shall be performed as required by the parties legally responsible for their maintenance.

Recommended Frequency of Service:

As further defined below, all stormwater components should be checked on a periodic basis and kept in full working order. Ultimately, the required frequency of inspection and service will depend on runoff quantities, pollutant loading, and clogging due to debris. At a minimum, we recommend that all stormwater components be inspected and serviced twice per year, once before winter begins and once during spring cleanup.

Qualified Inspector:

The inspections must be completed by an individual experienced in the construction and maintenance of stormwater drainage systems. Once every five years the inspections must be completed by a professional engineer.

Service Procedures:

1. Catch Basins & Drainage Inlets:

- a. Catch basins and drainage inlets shall be completely cleaned of accumulated debris and sediments at the completion of construction.
- b. For the first year, catch basins and drainage inlets shall be inspected on a quarterly basis.
- c. Any accumulated debris within the catch basins/inlets shall be removed and any repairs as required.
- d. From the second year onward, visual inspections shall occur twice per year, once in the spring and once in the fall, after fall cleanup of leaves has occurred.
- e. Accumulated debris within the catch basins/inlets shall be removed and repairs made as required.
- f. Accumulated sediments shall be removed at which time they are within 12 inches of the invert of the outlet pipe.
- g. Any additional maintenance required per the manufacturer's specifications shall also be completed.

2. Storm Drainage Piping and Manholes/Junction Boxes:

- a. All storm drainage piping shall be completely flushed of debris and accumulated sediment at the completion of construction.
- b. Manholes/Junction Boxes shall be inspected and repaired on an annual basis.

- c. Unless system performance indicates degradation of piping, comprehensive video inspection of storm drainage piping shall occur once every ten years.
- d. Any additional maintenance required per the manufacturer's specifications shall also be completed.

3. Stormwater Inlet/Control Structures:

- a. All control structures (orifice, weir, etc.) shall be completely cleaned of accumulated debris and sediments at the completion of construction. Any repairs shall be performed.
- b. For the first year, control structures (orifice, weir, etc.) shall be inspected on a quarterly basis.
- c. Any accumulated debris shall be removed and any repairs made to the control structures (orifice, weir, etc.) as required.
- d. From the second year onward, visual inspections shall occur twice per year, once in the spring and once in the fall, after fall cleanup of leaves has occurred.
- e. Accumulated debris shall be removed and repairs made as required.
- f. Any additional maintenance required per the manufacturer's specifications shall also be completed.

4. Drywells and Infiltration Systems:

- a. All drywells/infiltrators shall be completely cleaned of accumulated debris and sediments upon the completion of construction.
- b. For the first year, the drywells/infiltrators shall be inspected on a quarterly basis.
- c. Any accumulated debris within the drywells/infiltrators shall be removed and any repairs made to the units as required.
- d. From the second year onward, visual inspection shall occur twice per year, once in the spring and once in the fall, after fall cleanup of leaves has occurred.
- e. Accumulated debris within the units shall be removed and repairs made as required.
- f. Any additional maintenance required per the manufacturer's specifications shall also be completed.

5. Roof Gutters:

- a. Remove accumulated debris and inspect for damage. Any damage should be repaired as required.

Disposal of Debris and Sediment:

All debris and sediment removed from the stormwater structures and bioretention/biofiltration basins shall be disposed of legally. There shall be no dumping of silt or debris into or in proximity to any inland or tidal wetlands.

Maintenance Records:

The Owners(s) must maintain all records (logs, invoices, reports, data, etc.) and have them readily available for inspection at all times.

## Operations and Maintenance Log (Page 1 of 3)

#245 Route 32 Norwich New London Tpke. Montville, CT  
March 8, 2022 30,

Type of Inspection:  Spring  Fall  Other

Inspector's Name: \_\_\_\_\_ Date of Inspection: \_\_\_\_\_

Affiliation: \_\_\_\_\_ Phone #: \_\_\_\_\_

### Catch Basins & Drainage Inlets:

- Has accumulated debris been removed from grates?  Yes  No  N/A
- Do any basins require additional repair? (identify below):  Yes  No  N/A
- Have sumps been cleaned of sediment?  Yes  No  N/A

Notes:

### Storm Drainage Piping and Manholes/Junction Boxes:

- Has accumulated debris been removed?  Yes  No  N/A
- Do any manholes require additional repair? (identify below):  Yes  No  N/A
- Is there any evidence of stormwater piping failure?  Yes  No  N/A
- Has a comprehensive video inspection been completed?  Yes  No  N/A

Notes:

### Stormwater Control Structures:

- Has accumulated debris been removed?  Yes  No  N/A
- Are any repairs required? (identify below):  Yes  No  N/A
- Have orifices and weirs been cleaned of debris?  Yes  No  N/A

Notes:

## Operations and Maintenance Log (Page 2 of 3)

#245 Route 32 Norwich New London Tpke., Montville, CT

March 8, 2022

### Drainage Outfalls/Splash Pads/Scour Holes/Level Spreaders:

- Have all drainage outlets been cleared of debris?  Yes  No  N/A
- Have all outlet protections been inspected/repared?  Yes  No  N/A
- Have all erosion issues been repaired?  Yes  No  N/A

Notes:

### Drywells and Infiltration Systems:

- Have units been cleared of debris/sediments?  Yes  No  N/A
- Do units require additional repair? (identify below):  Yes  No  N/A
- Has draining times of system been verified?  Yes  No  N/A

Notes:

### Roof Gutters:

- Has accumulated debris been removed from gutters?  Yes  No  N/A
- Do any gutters require additional repair? (identify below):  Yes  No  N/A

Notes:

**Operations and Maintenance Log (Page 3 of 3)**

*#245 Route 32 Norwich New London Tpke. Montville CT*

*March 8, 2022*

Please make additional notes/observations and particular concerns below. Also record any additional maintenance that has been performed:

---

**Signature of Inspector:**

**Date:**

**SANITARY SEWER REPORT SECTION**

**PLUS MISCELLANEOUS INFORMATIONAL MAPS**



**FULLER ENGINEERING AND LAND SURVEYING, LLC**  
**525 John Street – Second Floor – Bridgeport, CT 06604**

**Phone: (203) 333-9465**

**Fax: (203) 336-1769**

PROJECT: RESIDENTIAL DEVELOPMENT @ #245 ROUTE 32  
 LOCATION: 245 NORWICH-NEW LONDON ROAD (ROUTE 32)  
 CLIENT: WESTERN GROUP, LLC

**SUMMATION OF PROPOSED SEWAGE FLOW:**

	QTY (unit or sqft)	GPD/UNIT	TOTAL GPD	
STUDIO	0	200	-	
1 BEDROOM	0	200	-	
2 BEDROOM	0	300	-	
3 BEDROOM	22	400	8,800.00	
			-	
<b>TOTAL</b>	<b>22</b>		<b>8,800.00</b>	<b>GPD</b>

7.48 GAL	1 CF	1,176.47 CF/day
1 day	24 hour	49.01960784 CF/HR
1 hour	3600 sec	0.013616558 CFS
MGD=	0.00880	MGD*4= 0.0352

INCLUDE PEAKING FACTOR OF 4

0.054466231 CFS

where:

GPD = Gallons per Day

MGD = Millions Gallons per Day

***Note: The Existing house is to remain unchanged with 3 Bedrooms in addition to 21 residential apartment units each with 3 bedrooms.***

**FULLER ENGINEERING AND LAND SURVEYING, LLC**  
**525 John Street – Second Floor – Bridgeport, CT 06604**

**Phone: (203) 333-9465**

**Fax: (203) 336-1769**

**CONVEYANCE CALCULATIONS:**

PROJECT: RESIDENTIAL DEVELOPMENT @ #245 ROUTE 32  
LOCATION: 245 NORWICH-NEW LONDON ROAD (ROUTE 32) MONTVILLE, CT  
CLIENT: WESTERN GROUP, LLC

PIPE: Existing 8" Sanitary Sewer in Town Road  
Pipe Diameter: 8 inches

MANNINGS EQUATION

$$R = \frac{A}{P_w} \quad 0.166667$$

Where	R:	Hydraulic radius (ft)	
	A:	Cross-sectional area (ft <sup>2</sup> )	0.349066
	P <sub>w</sub> :	Wetted Perimeter (ft)	2.094395

$$V = \frac{k R^{2/3} S^{1/2}}{n} \quad 2.452942$$

Where	V:	Mean Velocity (ft/s)	
	k:	1.49 for U.S. customary units, or 1.0 for S.I. units	
	n:	Manning's roughness value	0.012
	R:	Hydraulic Radius (ft)	0.166667
	S:	friction Slope (ft/ft)	0.004255

$$Q = VA \quad 0.856238 \text{ cfs}$$

Where	Q:	Flow Rate(cfs)	
	V:	Average velocity (ft/s)	

The Q for the proposed buildings plus storm infiltration going in to the system is 0.054 cfs which is less than the calculated Q; therefore OK  
The Existing 8" Lateral at 0.0043 slope is adequate.

**Notes:**

1. Storm runoff infiltration is considered at part of the safety factor.
2. Sewer system from development will be a force main system. Each building complex is to have a separate Grinder Pump System as Mfg. by e-ONE Sewer Systems.



Table 1 - Average Daily Flow on Specific Developments

TYPE OF DEVELOPMENT	UNIT	ADF (GPD/UNIT)
Auditorium	Seat	5
Automobile parking	1000 Gross square feet	25
Automobile repair garage	1000 Gross square feet	100
Bar	Seat	20
Bar: Public Areas & Tables	15 Gross square feet	20
Barber Shop	1000 Gross square feet	50
Beauty Salon	1000 Gross square feet	200
Carwash	Square feet inside	240
Church	Seat	5
Community center	Occupant	5
Country Club	Member	20
Factories (Exclusive of industrial waste)	Employee/shift	25
Factories (add for showers)	Employee/shift	+10
Gymnasium	1000 Gross square feet	300
Hospital - Convalescent/Rest Homes	Bed	150
Hospital	Bed	250
Jail	Inmate	85
Laboratory - commercial	1000 Gross square feet	300
Laundromat	Washer	400
Library / Museum	1000 Gross square feet	25
Manufacturing - industry	1000 Gross square feet	100
Medical building	1000 Gross square feet	300
Motel/Hotel	Room	100
Motel/Hotel (with cooking facilities)	Room	150
Office building	1000 Gross square feet	200
Residential -		
- single family dwelling, Townhouses	Dwelling unit	400
- bachelor/single, artist dwelling	Dwelling unit	100
- 1 Bedroom apartment or condo	Dwelling unit	200
- 2 Bedroom apartment or condo	Dwelling unit	300
- 3 Bedroom apartment of condo	Dwelling unit	400
- boarding house	Bed	85
- mobile home	Unit	200
- guest house with kitchen	Dwelling unit	300
Restaurant - fixed seat	Seat	50 or
Restaurant (dining area)	15 Gross square feet	50
Restaurant - Bakery, Doughnut Shop, take out	1000 Gross square feet	300
School - day care center	Child	10
School - elementary / junior high	Student	10
School - high school	Student	15
School - kindergarten	35 Gross square feet	10
Stadium/Theater - fixed seat	Seat	5
Stores, Shopping Centers, and Malls	1000 Gross square feet	100
University or College	Student	20
University Dormitory	Student	100
Veterinarian	1000 Gross square feet	300
Warehouse	1000 Gross square feet	25

**Table 1 Notes:**

Gross square feet: area included within the exterior of the surrounding walls of a building excluding courts.

Example Calculation - Assume a 10,000 sq. ft. office building is proposed. The estimated average daily flow is calculated as 10,000 sq. ft. x 200 gpd/1000 sq. ft. = 2000 gpd.

**Table 2 - Average Flow Rate based on Land Use and Area Density**

LAND USE / AREA DENSITY	UNIT	ADF (GPD/UNIT)
Low Density Residential (Single Family) (10 people / acre)	acre	1,000
Medium Density (Multi-Family) Residential (12 to 15 people / acre)	acre	1,200 - 1,500
High Density (Multi-Family) Residential (20 to 75 people / acre)	acre	2,000 - 7,500
Office & Institutional	acre	5,000
Commercial & Light Industrial	acre	5,000
Industrial	acre	10,000

The design Flow shall be calculated as follows:

$$\text{Design Flow} = \text{Average Daily Flow} \times \text{Peaking Factor}$$

where:

Design Flow = Flow used to design a sanitary sewer facility, gpd.

Average Daily Flow = Estimated average daily flow, gpd.

Peaking Factor = Ratio of peak hourly flow to average daily flow. A peaking factor of four (4) shall be used for all calculations unless directed otherwise by the Authority.

**Note:**

All developments with proposed ADF above 2,000 gpd are required to evaluate the capacity of the existing sanitary sewer system.



## PVC SEWER & STORM DRAINAGE PIPE

**Scope:** This submittal designates the general requirements for **Unplasticized Polyvinyl Chloride (PVC) Plastic PSM Sewer Pipe from compound with a cell classification 12454**, as defined in ASTM Standard D-1784.

**Pipe:** Pipe in trade size diameter of 4” through 15” shall meet the requirements of the latest ASTM D-3034 Standard. Pipe in trade sizes diameter of 18” and above shall meet the requirements of the latest ASTM Standard F-679. The above pipe shall conform to the requirements of CSA B-182.2. If integral gasketed bell ends are provided on the pipe, the pipe joint must meet the requirements of ASTM Standard D-3212, and the sealing gasket must conform to the requirements of ASTM Standard F-477 for sizes 4”-15”. The D-3034 normal pipe length will be 13’+/-1” laying length, (BNQ: 13’1½” min.) with other lengths available upon request. Pipe in trade size diameters of 4 and 6 inch are available with solvent-weld bells.

**Fittings:** Fittings shall conform to ASTM D-3034 & F-679 & CSA B-182.2.

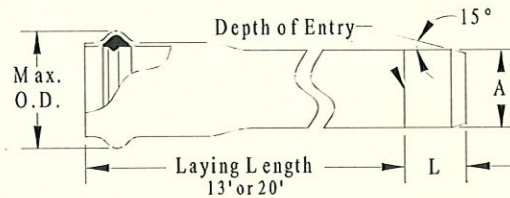

### Pipe Dimensions

ASTM D-3034			Minimum Wall Thickness				“L” Dimension Reference	
Nominal Size	Metric (m.m)	Average O.D.	SDR-41	SDR-35	SDR-26	SDR-23.5	Max. Bell OD	Max.
4”	100	4.215	----	0.120	0.162	0.178	5.050	3.500
6”	150	6.275	0.153	0.180	0.241	0.265	7.305	4.375
8”	200	8.400	0.205	0.240	0.323	----	9.605	4.375
10”	250	10.500	0.256	0.300	0.404	----	12.030	6.125
12”	300	12.500	0.305	0.360	0.481	----	14.100	6.000
15”	375	15.300	0.375	0.437	0.588	----	17.200	6.375
Min. Pipe Stiffness @ 5% Deflection			28 psi	46 psi	115 psi	153 psi		
ASTM F-679			*T-1 Min. (SDR-35)		*T-1 Min. (SDR-26)	**T-2 Min (SDR-35)		
18”	450	18.701	0.536		0.719	0.499	20.690	9.125
21”	500	22.047	0.632		0.847	0.588	24.260	10.125
24”	600	24.803	0.711		0.953	0.661	27.290	11.125
Min. Pipe Stiffness @ 5% Deflection			46 psi		115 psi	46 psi		

\*T-1 Is for material with a minimum cell classification of 12454B (400,000 psi min. modulus).

\*\*T-2 Is for material with a minimum cell classification of 12364C (500,000 psi min. modulus).

This information is for reference only and is not manufactured by National Pipe & Plastics, Inc.



**E/ONE**  
**EXTREME**  
S E R I E S

---

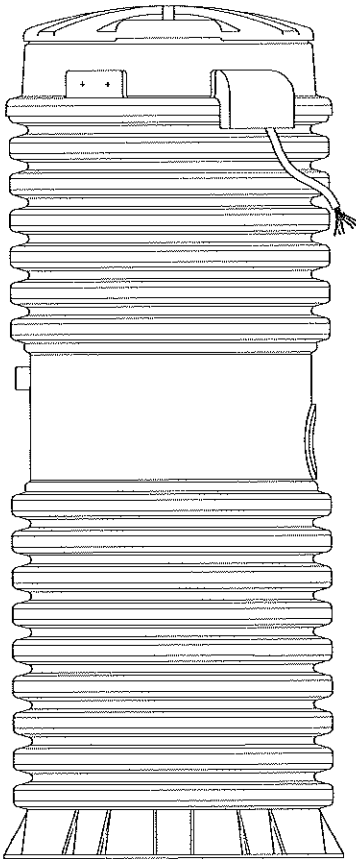

**Low Pressure  
Sewer Systems  
Using  
Environment One  
Grinder Pumps**

# Contents

---

Introduction .....	3
Advantages of LPS Systems .....	3
Description and Operation .....	3
Pump Operation .....	4
Pump Type .....	4
Motor Selection .....	5
Power Outages .....	7
Power Consumption .....	7
LPS System Design .....	9
Information Required .....	9
Grinder Pump Station Size Selection .....	9
Grinder Pump Placement .....	10
Pipe Selection .....	10
System Layout .....	11
Zone Designations .....	12
Completion of Pipe Schedule and Zone Analysis .....	14
Review .....	17
References .....	22
Manufacturer Evaluation List .....	30

## **Introduction**

---

Low pressure sewer (LPS) systems offer the designer new freedom in solving many problem situations that have defied reasonably economical solutions using the conventional approach.

Each LPS system design should be considered on the basis of its own unique circumstances. On such a basis, a sound choice between gravity and low pressure systems can be made.

General criteria aid the engineer in making a preliminary choice between several alternative systems: entirely low pressure, entirely gravity, entirely vacuum or a combination of systems. These criteria are presented and are intended to serve as a general guide. The final decision and design are the responsibility of the project consulting engineer, whose knowledge of local conditions, including construction costs, regulatory requirements and the client's particular needs, become vital to the preparation of the final designs and specifications.

## **Advantages of LPS Systems**

---

LPS systems have low initial (front end) cost compared to gravity systems, which have nearly all the total investment allocated in the first stage. With the LPS system, grinder pump costs are incurred only as construction progresses. These costs will be deferred for many years in certain types of development programs.

An LPS system is not subject to infiltration from ground water or from surface storm water entering through leaking pipe joints and manholes. With zero infiltration, treatment plants need not be sized to handle the peak flow rates caused by infiltration. Treatment efficiencies can be more consistent, and treatment plant operating costs decrease.

An LPS system may become the critical factor in determining whether "marginal" land can be economically developed. Many attractive sites have been considered unsuitable for development because of the excessive costs typically associated with conventional sewer systems — sites with hilly terrain, land with negligible slope, high water tables, poor percolation characteristics, rock, seasonal occupancy or low population density.

Many communities are planning to convert from septic tanks to central sewage collection and treatment systems to minimize health hazards and/or environmental deterioration. The major reduction in cost and the simplicity of installation of an LPS system have strong appeal for such community improvement programs. Small-diameter pipe pressure mains can be laid along existing roadways with minimum disruption to streets, sidewalks, lawns, driveways and underground utilities. Surface restoration costs are similarly minimized. Sewage delivered to the treatment plant (because it contains no infiltration) is more uniform in "strength," the volume is smaller, and peaks are greatly reduced.

## **Description and Operation**

---

Grinder pumps of approved design accomplish all pumping and sewage-grinding processes for small-diameter LPS systems.

The system consists of conventional drain, waste and vent (DWV) piping within the residence connected to the grinder pump inlet. The grinder pump may be installed above or below grade, indoors or outdoors. Depending on flow factors and model used, it may serve one or more resi-



dences, or several families in the case of apartment buildings.

Grinder pumps discharge a finely ground slurry into small-diameter pressure piping. In a completely pressurized collection system, all the piping downstream from the grinder pump (including laterals and mains) will normally be under low pressure. Pipe sizes will start at 1 1/4 inches for house connections (compared to 4 or 6 inches in gravity systems) and will be proportionally smaller than the equivalent gravity pipeline throughout the system. All pipes are arranged as zone networks without loops.

Depending on topography, size of the system and planned rate of buildout, appurtenances may include valve boxes, flushing arrangements, air release valves at significant high points, check valves and full-ported stops at the junction of each house connection with the low pressure sewer main.

## **Pump Operation**

---

Low pressure sewer systems have become feasible with the availability of the Environment One grinder pump, the reliability of which has been proven in almost 40 years of service. The grinder pump station provides adequate holding capacity, reliable grinding and pressure transport of a fine slurry to an existing gravity sewer, pump station or directly to a wastewater treatment plant.

In operation, the grinder pump station will handle sewage and many items that should not, but often do, appear in domestic wastewater. For example, plastic, wood, rubber and light metal objects can be routinely handled without jamming the grinder or clogging the pump or piping system. The grinder pump will discharge this slurry at a maximum rate of 15 gpm or 11 gpm at a pressure of 40 psig. Transporting sewage several thousand feet to a discharge point at a higher elevation is possible as long as the sum of the static and friction losses does not exceed design limits of 185 feet TDH (80 psig).

The grinder pump is actuated when the depth of the sewage in the tank reaches a predetermined "turn-on" level, and pumping continues until the "turn off" level is reached. The pump's running time is short, power consumption is low, and long pump life is ensured. The unit is protected against backflow from discharge lines by an integral check valve. Several grinder pump station models are available to satisfy various total and peak demand conditions.

## **Pump Type**

---

The semi-positive displacement pump in the grinder pump station has a nearly vertical H-Q curve. This is the best type of pump for successful parallel operation of many pumps into a system of common low pressure mains. Since each pump will be located at a different point along common low pressure mains and at various elevations, each pump should operate in an efficient and predictable manner, whether one pump or numerous pumps are operating at a given moment; the pumps in such a system do not have a single fixed "operating point," but must operate consistently over a wide range of heads that are continually, and often rapidly, changing.

The Environment One grinder pump has the capability of operating above the LPS system design criteria of 80 psig, or 185 feet (Figure 1). Based on the maximum daily number of pumps operating simultaneously (Table 3) versus the number of pumps connected to the system at the design pressure of 185 feet, the capability to operate significantly above the system's design pressure is mandatory in order for the system to operate properly during the approximately bimonthly peaks when

the “absolute maximum” numbers of pumps are operating. This feature also ensures that pumping will continue under those conditions when higher-than-normal pressure occurs in the pipeline.

System designs with calculated heads approaching the upper limits of recommended heads should be reviewed by Environment One application specialists. Contact your local Environment One Regional Sales Office or authorized distributor for a no-cost, computerized review of your design.

Occasionally during “normal” operation, there will be short periods when higher-than-design pressures will be experienced. These can result from a variety of causes including solids buildup (obstructions) or air bubbles.

Deposits of solids or air accumulation will be purged from the line since the pump continues to produce an essentially constant flow, even though the cross section of the pipeline has temporarily been reduced. Higher velocities through the reduced cross section will provide the scouring action needed to correct such conditions as soon as they start to appear.

These higher-than-expected pressure conditions are transitory occurrences. The only requirement is that no damage be done to the pumping equipment, pipelines or appurtenances during these occasional short periods. Environment One grinder pumps are driven by motors rated for continuous operation at 104 F/40 C above ambient temperature. They can operate at 50 percent above rated pressure for at least 5 minutes without excessive temperature rise. Based on the Albany, New York, demonstration project<sup>4</sup>, for this type of overload to last even as long as one minute would be rare.

## **Motor Selection**

---

A grinder pump station is an electromechanical system that depends on electric power for its operating, control and alarm functions. The design and selection of Environment One’s pump, motor, grinder and level-sensing controls were accomplished by optimizing the wastewater transport function of the unit within the necessary constraints for unattended, trouble-free operation in a residential environment.

A single grinder pump core is common to all models of Environment One grinder pumps (models DH071, DH151, DH152, DH272 and DH502). This central core contains all of the working and control elements of the unit and is powered by a 1 hp, 240v (or 120v), 1,725 rpm capacitor start, thermally protected induction motor. Each of these motor features was carefully considered in the design of the grinder pump station.

The pump should be considered as a residential appliance. For this reason, performing the grinding and pumping functions using no more than 1 hp to permit occasional use at 120v in older homes not wired for 240v is desirable. In order to achieve the high heads desired and provide constant flow at varying heads, the 1-hp motor is coupled to a pump of semi-positive displacement design (Figure 1).

At a rating of 1 hp and 1,725 rpm, the Environment One grinder pump develops more than 8.4 foot-pounds of torque. Motors used to drive centrifugal pumps are often rated at 2.0 hp at 3,450 rpm and may produce less torque. When handling residential sewage, grinding torque may be demanded during any portion of the starting or running cycle. When the pump stops (controlled by level) in the midst of grinding hard objects (e.g. tongue depressors, plastic items, etc.), it must, upon restarting, be able to provide sufficient torque to the grinder to overcome the resistance of any object remaining from the previous cycle.

Figure 1

# Grinder Pump Performance Characteristics

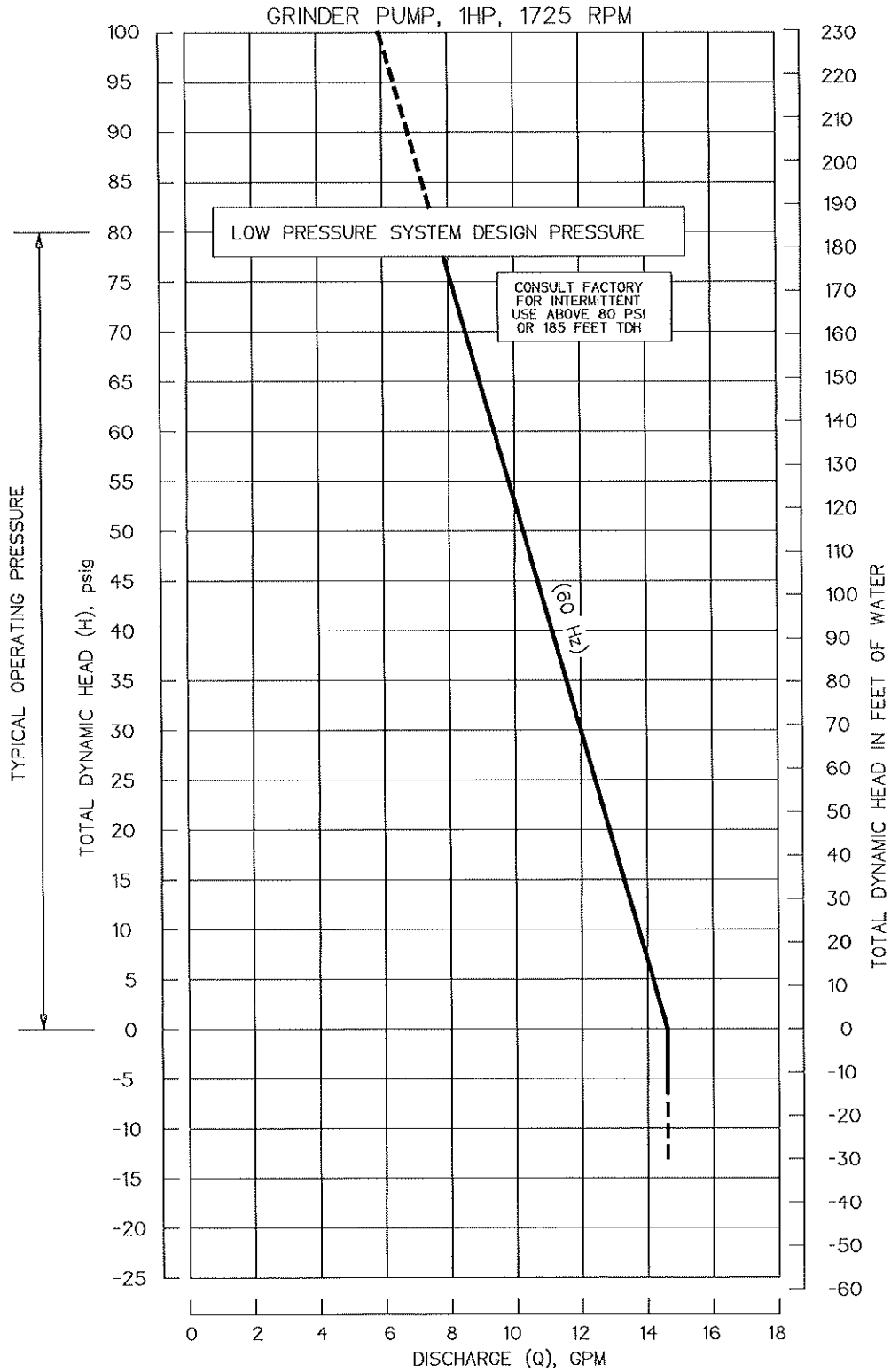

## Power Outages

---

Environment One grinder pump stations have adequate excess holding capacity to provide wastewater storage during most electrical power outages (Figure 2). This excess holding capacity is shown on curve A. Data from the Federal Power Commission on national electrical power outages is plotted as a cumulative distribution function (curve B). Note that only volume above the normal "turn-on" level was counted as available storage. The average flow of 1.54 gallons/hour/person is based on the actual measured flow over a one-year period at the Albany Demonstration Project<sup>4</sup>.

The local electrical power utility should be contacted to obtain a history on the power interruptions of the feeder(s) scheduled to serve the low pressure sewer site. From this data, curve B should be replotted to reflect local conditions. In those rare local areas where the frequency and/or the duration of outages exceed 7.5 hours, the use of Model DH151, with its greater holding capacity than that of the DH071, could be considered.

When power has been restored after a power outage, it is likely that nearly all the pumps in the system will try to operate simultaneously. Under these conditions, the dynamic head loss component of the total head will rise significantly. A number of pumps in the system would see a total back pressure high enough to cause the thermal overload protectors to automatically trip in a few minutes. Operation under conditions that could cause damage to the pumps or the system would be avoided. While these pumps are offline, other pumps in the system would be able to empty their tanks. After one to two minutes, the group that tripped off on thermal overload would cool and restart. The system back pressure would have been reduced and the group would be able to pump down normally. This process repeats itself automatically under the influence of each unit's own thermal protector, reliably restoring the system to normal operation.

## Power Consumption

---

Monthly power consumption of a residential grinder pump station is substantially less than that of other major appliances. The power consumption will vary based on the system operating parameters. The monthly cost can be approximated using the following equation and operating data:

$$\frac{* \text{ Watts} \times \text{ GPD} \times \text{ Days/Mo}}{** \text{ GPM} \times 60 \text{ min} \times 1000} = \text{ kwhr per month}$$

Discharge Pressure (PSI)	0	25	60	80
* Watts	690	770	1100	1400
** Flow (GPM)	15	12.4	9.3	7.7

As an example of the calculation for a typical single-family home using 250 GPD, pumping at 25 psi is:

$$\frac{770 \text{ W} \times 250 \text{ GPD} \times 30 \text{ Days}}{12.4 \text{ GPM} \times 60 \text{ min} \times 1000} = 7.76 \text{ kwhr per month}$$

Then, multiply the kilowatt hours by the current cost of electricity and you will have an approximate monthly cost of running the unit.

Figure 2

# Relationship of GP Storage Capacity to Power Outage Experience

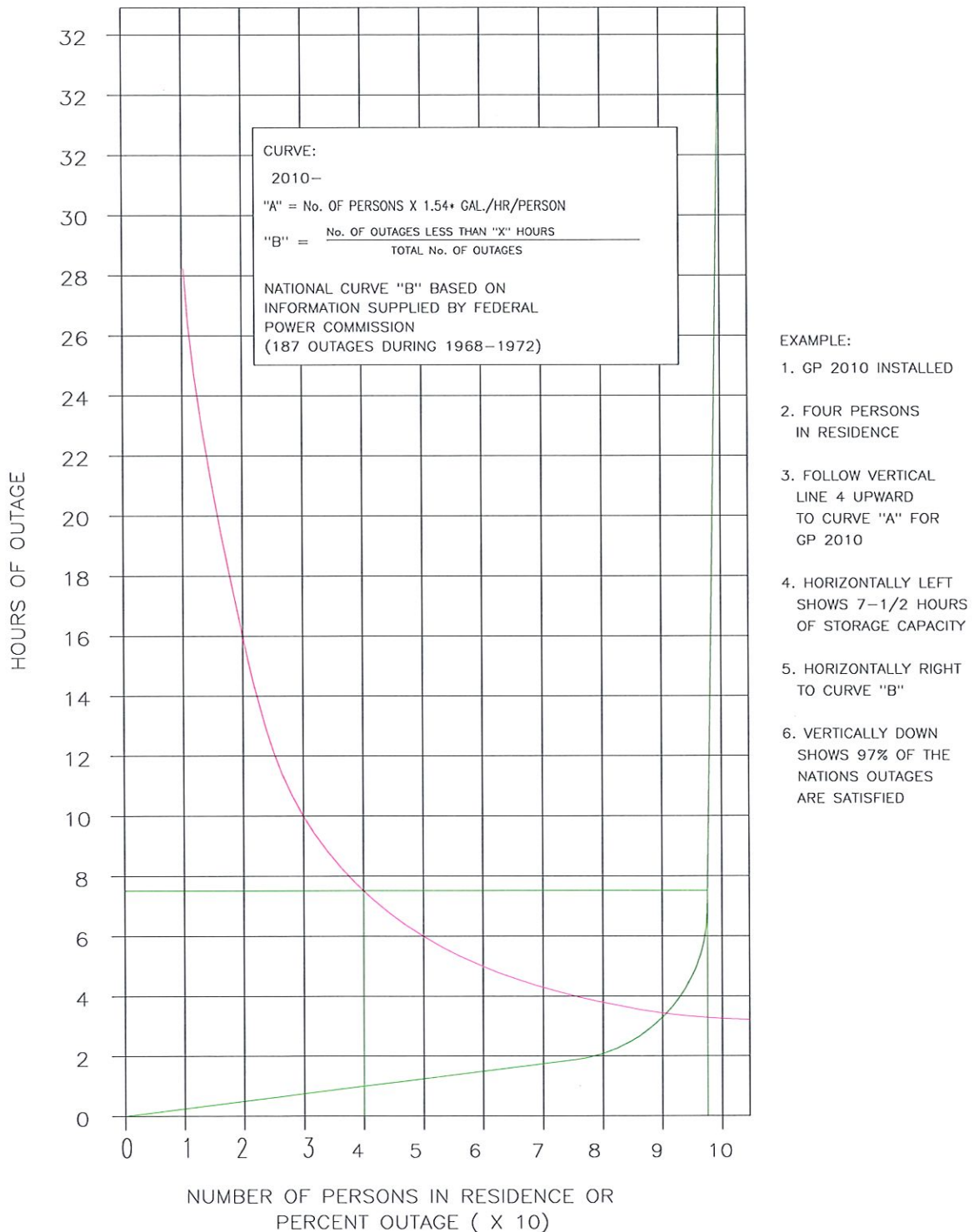

## LPS System Design

---

Once the initial analysis of a project has confirmed the feasibility of using the low-pressure approach, the completion of a preliminary system design is straightforward. This is primarily a result of two characteristics of E/One's semi-positive displacement pump: near-constant flow over the entire range of operating pressures and the ability of the pump to handle transient overpressures.

The balance of this section outlines a systematic approach to LPS system design, leading from pump model and pipe selection to a detailed zone and system analysis.

## Information Required

---

The information that should be assembled prior to initiation of the LPS system design includes:

- Topography map
- Soil conditions
- Climatic conditions (frost depth, low temperature and duration)
- Water table
- Applicable codes
- Discharge location
- Lot layout (with structures shown, if available)
- Total number of lots
- Dwelling type(s)
- Use and flow factors (seasonal occupancy or year-round, appliances, water supply sources)
- Area development sequence and timetable

## Grinder Pump Station Size Selection

---

Use this table to select grinder pump models for the types of occupancy to be served.

Model	Recommended Flow (gpd)	Adequate for Managing ...
DH071	up to 700	Flow from one average single-family home, and up to two average, single-family homes where codes allow and with consent of the factory.
DH151	up to 1,500	Flow from up to two average single-family homes, and up to six average, single-family homes where codes allow and with consent of the factory.
DH152	up to 3,000	Flow from up to four average single-family homes, and up to 12 average, single-family homes with consent of the factory.
DH272	up to 5,000	Flow from up to six average single-family homes, and up to 20 average, single-family homes with consent of the factory.
DH502	up to 6,000	Flow from up to nine average single-family homes,

and up to 24 average, single-family homes with consent of the factory.

Considerations include:

- Wetwell and discharge piping must be protected from freezing
- Model and basin size must be appropriate for incoming flows, including peak flows
- Appropriate alarm device must be used
- Suitable location

Daily flows above those recommended may exceed the tank's peak flow holding capacity and/or shorten the interval between pump overhauls. The company should be consulted if higher inflows are expected.

The final selection will have to be determined by the engineer on the basis of actual measurements or best estimates of the expected sewage flow.

## **Grinder Pump Placement**

---

The most economical location for installation of the grinder pump station is in the basement of the building it will serve. However, due consideration must be given when choosing an indoor location. If there is a risk of damage to items located in the basement level, other provisions should be made during basement installation or an outdoor unit should be considered.

Considerations such as ownership of the pumps by a municipality or private organization and/or the need for outdoor accessibility frequently dictate outdoor, in-ground installations. For outdoor installations, all GP models are available with high density polyethylene (HDPE) integral accessways ranging in height up to 10 feet. By keeping the unit as close as possible to the building, the lengths of gravity sewer and wiring will be minimized, keeping installation costs lower while reducing the chances of infiltration in the gravity flow section.

AC power from the building being served should be used for the grinder pump. Separate power sources add to installation and O&M costs, decrease overall reliability and frequently represent an aesthetic issue.

When two dwellings are to be served by a single unit, the station is usually placed in a position requiring the shortest gravity drains from each home. With multi-family buildings, more than one grinder pump may be required.

## **Pipe Selection**

---

The final determination of the type of pipe to be used is the responsibility of the consulting engineer. In addition, the requirements of local codes, soil, terrain, water and weather conditions that prevail will guide this decision.

Although pipe fabricated from any approved material may be used, most LPS systems have been built with PVC and HDPE pipe. Continuous coils of small-diameter, HDPE pipe can be installed with automatic trenching machines and horizontal drilling machines to sewer areas at lower cost.

Nominal Pipe Size (in.)	Sch 40 PVC	SDR 21 PVC	SDR 11 HDPE
1 1/4	7.8	9.2	7.4
1 1/2	10.6	12.1	9.9
2	17.4	18.8	15.4
2 1/2	23.9	27.6	—
3	38.4	40.9	33.5
4	66.1	67.5	55.3
5	103.7	103.1	84.5
6	150.0	146.0	119.9
8	260.0	249.0	203.2

Parameter	Sch 40	SDR 21
Wall Thickness, in.	0.154	0.113
Inside Diameter, in.	2.067	2.149
50 gpm Friction Loss, ft/100 ft	4.16	3.44

Table 1 compares the water capacity of two types of PVC pipe commonly used: SDR-21 and Sch 40, and one type of HDPE, SDR-11. All three have adequate pressure ratings for low pressure sewer service.

Although both types of PVC pipes are suitable, the three parameters compared in Table 2 illustrate why SDR-21 is suggested as a good compromise between capacity, strength, friction loss characteristics and cost.

## **System Layout**

A preliminary sketch of the entire pressure sewer system should be prepared (Figure 3). Pump models should be selected and their location (elevation) should be noted. The location and direction of flow of each lateral, zone and main, and the point of discharge should be shown.

The system should be designed to give the shortest runs and the fewest abrupt changes in direction. "Loops" in the system must be avoided as they lead to unpredictable and uneven distribution of flow.

Although not shown in Figure 3, the elevation of the shutoff valve of the lowest-lying pump in each zone should be recorded and used in the final determination of static head loss. Since Environment One grinder pumps are semi-positive displacement and relatively insensitive to changes in head, precisely surveyed profiles are unnecessary.

Air/vacuum valves, air release valves and combination air valves serve to prevent the concentration of air at high points within a system. This is accomplished by exhausting large quantities of air as the system is filled and also by releasing pockets of air as they accumulate while the system is in operation and under pressure. Air/vacuum valves and combination air valves also serve to prevent a potentially destructive vacuum from forming.

Air/vacuum valves should be installed at all system high points and significant changes in grade. Combination air valves should be installed at those high points where air pockets can form. Air release valves should be installed at intervals of 2,000 to 2,500 feet on all long horizontal runs that lack a clearly defined high point.



Air relief valves should be installed at the beginning of each downward leg in the system that exhibits a 30-foot or more drop. Trapped pockets of air in the system not only add static head, but also increase friction losses by reducing the cross sectional area available for flow. Air will accumulate in downhill runs preceded by an uphill run.

Long ascending or descending lines require air and vacuum or dual-function valves placed at approximately 2000-foot intervals. Long horizontal runs require dual function valves placed at approximately 2000-foot intervals.

Pressure air release valves allow air and/or gas to continuously and automatically released from a pressurized liquid system. If air or gas pockets collect at the high points in a pumped system, then those pressurized air pockets can begin to displace usable pipe cross section. As the cross section of the pipe artificially decreases, the pump sees this situation as increased resistance to its ability to force the liquid through the pipe.

Air relief valves at high points may be necessary, depending on total system head, flow velocity and the particular profile. The engineer should consult Environment One in cases where trapped air is considered a potential problem.

Cleanout and flushing stations should be incorporated into the pipe layout. In general, cleanouts should be installed at the terminal end of each main, every 1,000 to 1,500 feet on straight runs of pipe, and whenever two or more mains come together and feed into another main.

## **Zone Designations**

---

The LPS system illustrated in Figure 3 contains 72 pumps and is divided into 14 individually numbered zones. Division into zones facilitates final selection of pipe sizes, which are appropriate in relation to the requirements that flow velocity in the system is adequate and that both static and dynamic head losses are within design criteria. Assignment of individual zones follows from the relationship between the accumulating total number of pumps in a system to the predicted number that will periodically operate simultaneously (Table 3).

Table 4 was initially developed after careful analysis of more than 58,000 pump events in a 307-day period during the Albany project (4). It was extended for larger systems by application of probability theory. The validity of this table has since been confirmed by actual operating experience with thousands of large and small LPS systems during a 34-year period.

Using Figure 3, the actual exercise of assigning zones is largely mechanical. The single pump farthest from the discharge point in any main or lateral constitutes a zone. This and downstream pumps along the main are accumulated until their aggregate number is sufficient to increase the number of pumps in simultaneous operations by one, i.e., until the predicted maximum flow increases by 11 gpm.

Figure 3 shows that zones 1, 2 and 3 end when the number of pumps connected total 3, 6 and 9, and the number of pumps in daily simultaneous operation are 2, 3 and 4, respectively.

Any place where two or more sections of main join, or where the outfall is reached, also determines the end of a zone. This design rule takes precedence over the procedure stated above, as seen in

Figure 3

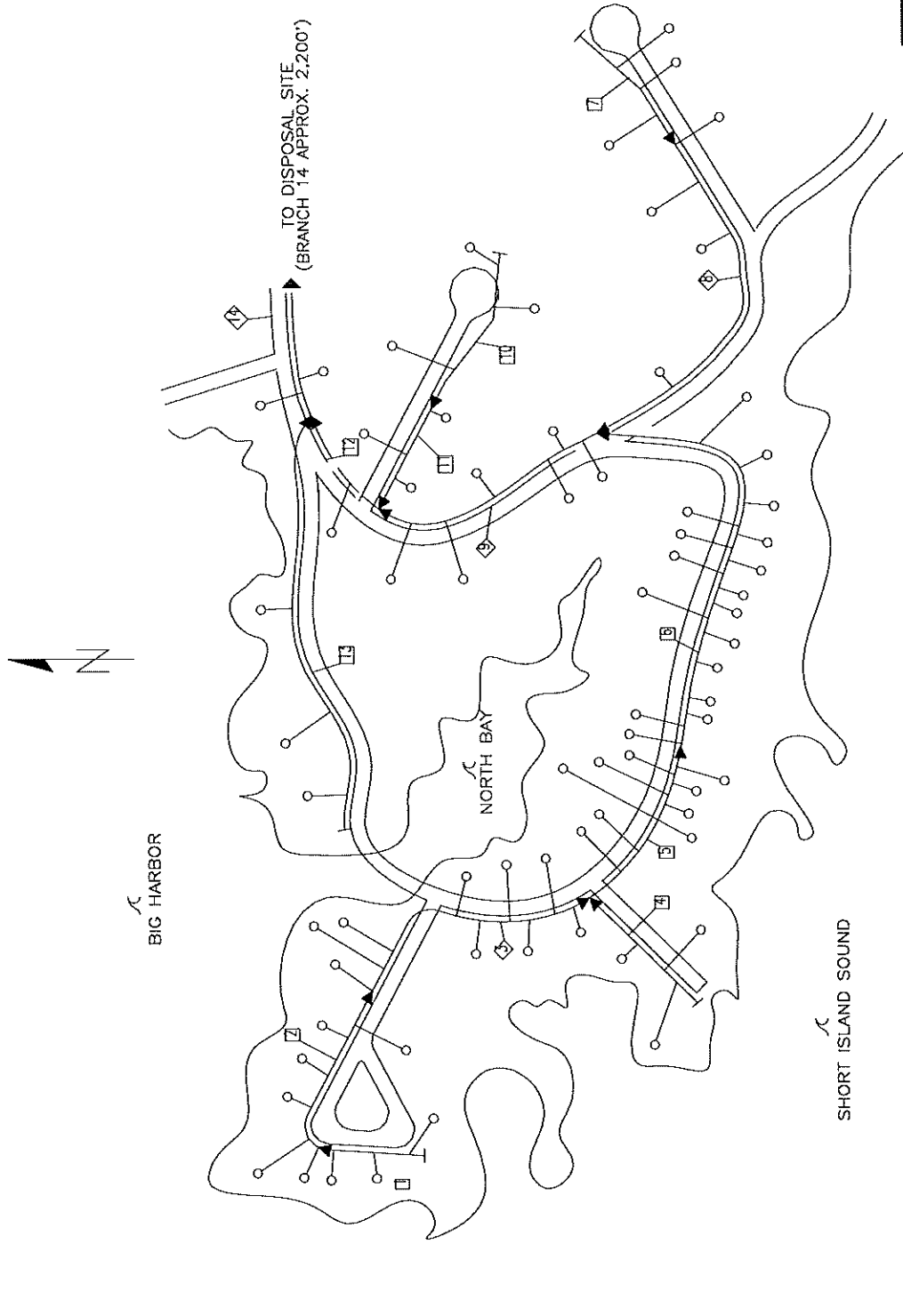

<b>e one</b>	
PRESSURE SEWER	
FIRST MADE FOR -	-
DRAWING NUMBER	SH OF REV
AE-732	-

SYSTEM FLOW DIAGRAM  
ILLUSTRATED EXAMPLE

- LEGEND:
- FLUSHING CONNECTION
  - INLINE FLUSHING CONNECTION
  - BRANCH DIVIDER & FLOW INDICATOR
  - GRINDER PUMP STATION
  - ZONE NUMBER
  - DISCHARGE

zones 3, 4, 6, 8, 9, 11, 12, 13 and 14.

## Completion of Pipe Schedule and Zone Analysis

The data recorded on the System Flow Diagram (Figure 3) is then transferred to Table 4.

Table 4 Column No.	Designation
1	Zone Number
2	Connects to Zone
3	Number of Pumps in Zone
4	Accumulated Pumps in Zone
11	Length of Main this Zone in Feet

Column 4 is completed by referring to Table 3, where the maximum number of pumps in simultaneous operation is given as a function of the number of pumps upstream from the end of the particular zone. The output of each zone will vary slightly with head requirements, but under typical conditions, the flow is approximately 11 gpm. Calculate the maximum anticipated flow for each zone by multiplying the number of simultaneous operations in Column 7 by 11 gpm and record the results in Column 8.

To complete columns 9, 10, 12 and 13, refer to Flow Velocity and Friction Head Loss table for the type of pipe selected — in this case, Table 5 for SDR-21. It will be seen that the engineer will frequently be presented with more than one option when selecting pipe size. Sometimes a compromise in pipe size will be required to meet present needs as well as planned future development. As a general rule, pipe sizes should be selected to minimize friction losses while keeping velocity near or above 2 feet per second.

For example, Zone 1 has a maximum of two pumps running (Column 7). Table 5 offers a choice of 1.25-inch, 1.5-inch or 2-inch pipe. 1.5-inch pipe is selected since flow velocity equals

Table 3 MAXIMUM NUMBER OF GRINDER PUMP CORES OPERATING DAILY	
Number of Grinder Pump Cores Connected	Maximum Daily Number of Grinder Pump Cores Operating Simultaneously
1	1
2-3	2
4-9	3
10-18	4
19-30	5
31-50	6
51-80	7
81-113	8
114-146	9
147-179	10
180-212	11
213-245	12
246-278	13
279-311	14
312-344	15
345-377	16
378-410	17
411-443	18
444-476	19
477-509	20
510-542	21
543-575	22
576-608	23
609-641	24
642-674	25
675-707	26
708-740	27
741-773	28
774-806	29
807-839	30
840-872	31
873-905	32
906-938	33
939-971	34
972-1,004	35

BY:		PRELIMINARY LOW-PRESSURE SEWER SYSTEM PIPE SCHEDULE AND ZONE ANALYSIS OF:														Environment/One CORPORATION		
PIPE: SDR 21 PVC		Illustrated Example Table 4														AE		
PREPARED FOR:		SHEET NO.														REV		
1	2	3	4	5	6	7	8	9	10	11	12	13	14	15	16	17	18	
ZONE NO.	CONN. TO ZONE	NO. PUMPS IN ZONE	ACCUM. PUMPS IN ZONE	GAL/DAY PER CORE	MAX. FLOW PER CORE	MAX. SIM OPS	MAX. FLOW (gpm)	PIPE SIZE (in)	MAX. VELOCITY (FPS)	LENGTH OF MAIN THIS ZONE	FRICTION LOSS FACTOR (ft/100 ft)	FRICTION LOSS THIS ZONE	ACCUM. FRICTION LOSS (ft)	MAX. MAIN ELEV.	MIN. PUMP ELEV.	STATIC HEAD (ft)	TOTAL DYNAMIC HEAD (ft)	
1	2	3	3	200	11	2	22	1.5	3.04	205	2.15	4.41	73.41	40	10	30	103.41	
2	3	6	9	200	11	3	33	2.0	2.92	380	1.54	5.86	69.00	40	10	30	99.00	
3	5	9	18	200	11	4	44	2.0	3.89	630	2.63	16.56	63.14	40	5	35	98.14	
4	5	3	3	200	11	2	22	1.5	3.04	310	2.15	8.46	53.25	40	5	35	88.25	
5	6	9	30	200	11	5	55	3.0	2.24	800	0.60	4.83	46.58	40	5	35	81.58	
6	9	17	47	200	11	6	66	3.0	2.69	1,000	0.85	8.46	41.75	40	5	35	76.75	
7	8	3	3	200	11	2	22	1.5	3.04	175	2.15	3.77	49.56	40	5	35	84.56	
8	9	4	7	200	11	3	33	2.0	2.92	810	1.54	12.50	45.80	40	30	10	55.80	
9	12	6	60	200	11	7	77	3.0	3.14	520	1.12	5.85	33.30	40	10	30	63.30	
10	11	3	3	200	11	2	22	1.5	3.04	230	2.15	4.95	37.03	40	10	30	67.03	
11	12	3	6	200	11	3	33	2.0	2.92	300	1.54	4.63	32.08	40	10	30	62.08	
12	14	1	67	200	11	7	77	3.0	3.14	240	1.12	2.70	27.45	40	10	30	57.45	
13	14	3	3	200	11	2	22	1.5	3.04	985	2.15	21.19	45.94	40	5	35	80.94	
14	14	2	72	200	11	7	77	3.0	3.14	2,200	1.12	24.75	24.75	40	30	10	34.75	

3.04 ft/sec and friction loss equals 2.15 ft/100 ft. Since the zone is 205 feet in length (Column 11), the total friction loss (Column 13) is:

$$HF = (2.15 \text{ ft}/100 \text{ ft})(205 \text{ ft}) = 4.41 \text{ ft}$$

For Zone 14, with 72 upstream pumps, it is seen that a maximum of seven pumps can be running simultaneously. Table 5 provides options of:

$$3\text{-inch pipe: } V = 3.14 \text{ ft}/\text{sec}; HF = 1.12 \text{ ft}/100 \text{ ft}$$

or

$$4\text{-inch pipe: } V = 1.90 \text{ ft}/\text{sec}; HF = 0.33 \text{ ft}/100 \text{ ft}$$

The smaller-diameter 3-inch pipe is selected because of the increased velocities, especially with the TDH below 185 feet. A choice of 3-inch pipe would lead to a friction loss in this zone of:

$$HF = (1.12 \text{ ft}/100 \text{ ft}) (2200 \text{ ft}) = 24.75 \text{ ft}$$

Accumulated friction loss (Column 14) for each zone is next determined by adding the friction loss for each zone from the system outfall (Zone 14) to the zone in question. Thus, from Figure 3 it is seen that the accumulated friction loss for Zone 1 is:

Zone Number	Friction Loss (ft)
14	24.75
12	2.70
9	5.85
6	8.46
5	4.83
3	16.56
2	5.86
1	4.41

$$73.41 \text{ ft} = \text{Accumulated friction loss, Zone 1}$$

The same summation is completed for each zone.

To complete the hydraulic analysis, refer to the drawing contours and record in Column 15 the maximum line elevation between the point of discharge and the zone under consideration. In Column 16, record the elevation of the lowest pump in the zone. Subtract the values in Column 16 from

those in Column 15 and record only positive elevation differentials in Column 17. Add the values in Column 14 to those in Column 17 and record the total in Column 18 to show the maximum combination of friction and static head a pump will experience at any given point in the system.

## Review

---

The accumulated data in Table 4 should finally be reviewed for conformity with the criteria of flow velocity greater than or equal to 2.0 ft/sec and total design head less than or equal to 185 feet. If the system pressure exceeds 92 feet, the number of cores operating will remain the same and the flow from each pump will be reduced from 11 gpm to 9 gpm.

Data should be reviewed to determine whether system improvements could result from construction modifications. As an example, deeper burial of pipe in one or two critical high-elevation zones might bring the entire system into compliance with design criteria. Environment One should be consulted in marginal cases and/or concerning:

- Odor control issues
- Frost protection issues
- Excessive static head conditions
- Excessive total dynamic head conditions
- Unusual applications



**Table 5**  
**SDR 21 PVC PIPE**

Flow Velocity and Friction Head Loss vs Pumps in Simultaneous Operation (C = 150)

	1 1/4 in.		1 1/2 in.		2 in.		2 1/2 in.		3 in.		4 in.		5 in.		6 in.		8 in.		
<b>N</b>	<b>V</b>	<b>H<sub>F</sub></b>	<b>V</b>	<b>H<sub>F</sub></b>	<b>V</b>	<b>H<sub>F</sub></b>	<b>V</b>	<b>H<sub>F</sub></b>	<b>V</b>	<b>H<sub>F</sub></b>	<b>V</b>	<b>H<sub>F</sub></b>	<b>V</b>	<b>H<sub>F</sub></b>	<b>V</b>	<b>H<sub>F</sub></b>	<b>V</b>	<b>H<sub>F</sub></b>	<b>N</b>
1	1.99	1.15	1.52	0.60															1
2	3.99	4.16	3.04	2.15	1.95	0.73													2
3	5.98	8.82	4.56	4.56	2.92	1.54	1.99	0.61											3
4	7.97	15.02	6.08	7.77	3.89	2.63	2.66	1.04	1.79	0.40									4
5					4.87	3.97	3.32	1.57	2.24	0.60									5
6					5.84	5.57	3.99	2.20	2.69	0.85									6
7					6.81	7.41	4.65	2.93	3.14	1.12	1.90	0.33							7
8							5.32	3.75	3.59	1.44	2.17	0.42							8
9							5.98	4.66	4.04	1.79	2.44	0.53							9
10							6.64	5.67	4.49	2.18	2.71	0.64							10
11									4.93	2.60	2.98	0.76	1.95	0.27					11
12									5.38	3.05	3.25	0.90	2.13	0.32					12
13									5.83	3.54	3.52	1.04	2.31	0.37					13
14									6.28	4.06	3.80	1.19	2.48	0.43					14
15											4.07	1.36	2.66	0.48	1.88	0.21			15
16											4.34	1.53	2.84	0.55	2.00	0.23			16
17											4.61	1.71	3.02	0.61	2.13	0.26			17
18											4.88	1.90	3.19	0.68	2.25	0.29			18
19											5.15	2.10	3.37	0.75	2.38	0.32			19
20											5.42	2.31	3.55	0.82	2.50	0.35			20
21											5.69	2.53	3.73	0.90	2.63	0.39			21
22											5.96	2.76	3.90	0.98	2.75	0.42			22
23											6.24	2.99	4.08	1.07	2.88	0.46			23
24													4.26	1.16	3.00	0.49			24
25													4.44	1.25	3.13	0.53			25
26													4.61	1.34	3.25	0.57			26
27													4.79	1.44	3.38	0.61	1.99	0.17	27
28													4.97	1.54	3.50	0.66	2.07	0.18	28
29													5.15	1.64	3.63	0.70	2.14	0.19	29
30													5.32	1.75	3.75	0.75	2.21	0.21	30
31													5.50	1.86	3.88	0.79	2.29	0.22	31
32													5.68	1.97	4.01	0.84	2.36	0.23	32
33													5.86	2.08	4.13	0.89	2.44	0.25	33
34													6.03	2.20	4.26	0.94	2.51	0.26	34
35													6.21	2.32	4.38	0.99	2.58	0.28	35
36															4.51	1.05	2.66	0.29	36
37															4.63	1.10	2.73	0.30	37
38															4.76	1.16	2.81	0.32	38
39															4.88	1.21	2.88	0.34	39
40															5.01	1.27	2.95	0.35	40
41															5.13	1.33	3.03	0.37	41
42															5.26	1.39	3.10	0.39	42
43															5.38	1.45	3.17	0.40	43
44															5.51	1.52	3.25	0.42	44
45															5.63	1.58	3.32	0.44	45
46															5.76	1.65	3.40	0.46	46
47															5.88	1.72	3.47	0.47	47
48															6.01	1.78	3.54	0.49	48
49															6.13	1.85	3.62	0.51	49
50															6.26	1.92	3.69	0.53	50

Head Loss Calculations  
From Modified Hazen - Williams Formula

$$H_F = .2083 \left[ \left( \frac{100}{C} \right)^{1.852} \times \frac{q^{1.852}}{d^{4.8655}} \right]$$

$$V = .3208 \frac{q}{A}$$

$$A = \frac{d^2 \pi}{4} = \text{cross-sectional flow, sq. in.}$$

C = 150

q = flow in gallons per minute  
d = I.D. of pipe in inches =  
[average O.D. - (2 x min. wall thickness)]

N = Number of pumps operating at 11 gpm  
V = Flow velocity in ft/sec  
H<sub>F</sub> = Friction head loss in ft/100 ft of pipe



**Table 6**  
**SCHEDULE 40 PVC PIPE**

Flow Velocity and Friction Head Loss vs Pumps in Simultaneous Operation (C = 150)

	1 1/4 in.		1 1/2 in.		2 in.		2 1/2 in.		3 in.		4 in.		5 in.		6 in.		8 in.		
N	V	H <sub>F</sub>	V	H <sub>F</sub>	V	H <sub>F</sub>	V	H <sub>F</sub>	V	H <sub>F</sub>	V	H <sub>F</sub>	V	H <sub>F</sub>	V	H <sub>F</sub>	V	H <sub>F</sub>	N
1	2.36	1.74	1.73	0.82	1.05	0.24													1
2	4.72	6.28	3.47	2.97	2.10	0.88	1.47	0.37											2
3	7.08	13.31	5.20	6.29	3.15	1.86	2.21	0.79											3
4			6.93	10.71	4.21	3.18	2.95	1.34	1.91	0.46									4
5					5.26	4.80	3.68	2.02	2.39	0.70									5
6					6.31	6.73	4.42	2.83	2.87	0.99									6
7							5.16	3.77	3.34	1.31	1.94	0.35							7
8							5.89	4.83	3.82	1.68	2.22	0.45							8
9							6.63	6.01	4.30	2.09	2.49	0.56							9
10									4.78	2.54	2.77	0.68							10
11									5.25	3.03	3.05	0.81	1.94	0.27					11
12									5.73	3.56	3.33	0.95	2.12	0.32					12
13									6.21	4.13	3.60	1.10	2.29	0.37					13
14											3.88	1.26	2.47	0.42					14
15											4.16	1.43	2.65	0.48					15
16											4.44	1.62	2.82	0.54	1.95	0.22			16
17											4.71	1.81	3.00	0.60	2.08	0.25			17
18											4.99	2.01	3.17	0.67	2.20	0.27			18
19											5.27	2.22	3.35	0.74	2.32	0.30			19
20											5.54	2.44	3.53	0.81	2.44	0.33			20
21											5.82	2.67	3.70	0.89	2.56	0.36			21
22											6.10	2.91	3.88	0.97	2.69	0.40			22
23													4.06	1.05	2.81	0.43			23
24													4.23	1.14	2.93	0.47			24
25													4.41	1.23	3.05	0.50			25
26													4.59	1.32	3.17	0.54			26
27													4.76	1.42	3.30	0.58			27
28													4.94	1.52	3.42	0.62	1.98	0.16	28
29													5.11	1.62	3.54	0.66	2.05	0.17	29
30													5.29	1.72	3.66	0.70	2.12	0.19	30
31													5.47	1.83	3.79	0.75	2.19	0.20	31
32													5.64	1.94	3.91	0.79	2.26	0.21	32
33													5.82	2.06	4.03	0.84	2.33	0.22	33
34													6.00	2.17	4.15	0.89	2.40	0.23	34
35													6.17	2.29	4.27	0.94	2.47	0.25	35
36															4.40	0.99	2.54	0.26	36
37															4.52	1.04	2.61	0.27	37
38															4.64	1.09	2.68	0.29	38
39															4.76	1.15	2.75	0.30	39
40															4.88	1.20	2.82	0.32	40
41															5.01	1.26	2.89	0.33	41
42															5.13	1.31	2.96	0.35	42
43															5.25	1.37	3.03	0.36	43
44															5.37	1.43	3.11	0.38	44
45															5.49	1.49	3.18	0.39	45
46															5.62	1.56	3.25	0.41	46
47															5.74	1.62	3.32	0.43	47
48															5.86	1.68	3.39	0.44	48
49															5.98	1.75	3.46	0.46	49
50															6.11	1.81	3.53	0.48	50
26	Head Loss Calculations																		
27	From Modified Hazen - Williams Formula																		
28	$H_F = .2083 \left[ \left( \frac{100}{C} \right)^{1.852} \times \frac{q^{1.852}}{d^{4.8655}} \right]$																		
29	$V = .3208 \frac{q}{A}$																		
30	$A = \frac{d^2 \pi}{4} = \text{cross-sectional flow, sq. in.}$																		
31	C = 150																		
32	q = flow in gallons per minute																		
33	d = I.D. of pipe in inches =																		
34	[average O.D. - (2 x min. wall thickness)]																		

**Table 7**  
**SDR 11 HDPE PIPE**

Flow Velocity and Friction Head Loss vs Pumps in Simultaneous Operation (C = 155)

	1 1/4 in.		1 1/2 in.		2 in.		3 in.		4 in.		5 in.		6 in.		8 in.		
<b>N</b>	<b>V</b>	<b>H<sub>F</sub></b>	<b>V</b>	<b>H<sub>F</sub></b>	<b>V</b>	<b>H<sub>F</sub></b>	<b>V</b>	<b>H<sub>F</sub></b>	<b>V</b>	<b>H<sub>F</sub></b>	<b>V</b>	<b>H<sub>F</sub></b>	<b>V</b>	<b>H<sub>F</sub></b>	<b>V</b>	<b>H<sub>F</sub></b>	<b>N</b>
1	2.47	1.84	1.86	0.92													1
2	4.95	6.63	3.72	3.32	2.38	1.12											2
3	7.42	14.04	5.58	7.03	3.57	2.37	1.64	0.36									3
4			7.44	11.98	4.76	4.04	2.19	0.61									4
5					5.95	6.11	2.74	0.92									5
6					7.14	8.56	3.29	1.30	1.99	0.38							6
7							3.83	1.72	2.32	0.51							7
8							4.38	2.21	2.65	0.65							8
9							4.93	2.75	2.98	0.81	1.95	0.29					9
10							5.48	3.34	3.31	0.98	2.17	0.35					10
11							6.03	3.98	3.65	1.17	2.39	0.42					11
12									3.98	1.38	2.60	0.49					12
13									4.31	1.60	2.82	0.57	1.99	0.24			13
14									4.64	1.83	3.04	0.65	2.14	0.28			14
15									4.97	2.08	3.25	0.74	2.29	0.32			15
16									5.30	2.35	3.47	0.84	2.45	0.36			16
17									5.63	2.63	3.69	0.94	2.60	0.40			17
18									5.97	2.92	3.90	1.04	2.75	0.44			18
19									6.30	3.23	4.12	1.15	2.90	0.49			19
20											4.34	1.27	3.06	0.54			20
21											4.56	1.39	3.21	0.59			21
22											4.77	1.51	3.36	0.64	1.98	0.18	22
23											4.99	1.64	3.52	0.70	2.08	0.19	23
24											5.21	1.77	3.67	0.76	2.17	0.21	24
25											5.42	1.91	3.82	0.82	2.26	0.23	25
26											5.64	2.06	3.98	0.88	2.35	0.24	26
27											5.86	2.21	4.13	0.94	2.44	0.26	27
28											6.07	2.36	4.28	1.01	2.53	0.28	28
29													4.43	1.08	2.62	0.30	29
30													4.59	1.15	2.71	0.32	30
31													4.74	1.22	2.80	0.34	31
32													4.89	1.29	2.89	0.36	32
33													5.05	1.37	2.98	0.38	33
34													5.20	1.44	3.07	0.40	34
35													5.35	1.52	3.16	0.42	35
36													5.50	1.60	3.25	0.44	36
37													5.66	1.69	3.34	0.47	37
38													5.81	1.77	3.43	0.49	38
39													5.96	1.86	3.52	0.52	39
40													6.12	1.95	3.61	0.54	40
41															3.70	0.57	41
42															3.79	0.59	42
43															3.88	0.62	43
44															3.97	0.65	44
45															4.06	0.67	45
46															4.15	0.70	46
47															4.24	0.73	47
48															4.33	0.76	48
49															4.42	0.79	49
50															4.51	0.82	50

**Head Loss Calculations  
From Modified Hazen - Williams Formula**

$$H_F = .2083 \left[ \left( \frac{100}{C} \right)^{1.852} \times \frac{q^{1.852}}{d^{4.8655}} \right]$$

$$V = .3208 \frac{q}{A}$$

$$A = \frac{d^2 \pi}{4} = \text{cross-sectional flow, sq. in.}$$

C = 150

q = flow in gallons per minute

d = I.D. of pipe in inches =

[average O.D. - (2 x min. wall thickness)]

## References

---

1. Carcich, I., Hetling, L.J., and Farrell, R.P. "A Pressure Sewer System Demonstration," EPA-R2-72-091, Office of Research and Monitoring, U.S. Environmental Protection Agency, Washington, D.C., November 1972.
2. Farrell, R.P. "Long-Term Observation of Wastewater Observation Stations," TM-2, American Society of Civil Engineers, April 1968.
3. "Handbook of PVC Pipe: Design and Construction," Uni-Bell PVC Pipe Association, Dallas, Texas, Second Edition, 1982.
4. Hicks, T.G., and Edwards, T. W. "Pump Application Engineering," McGraw Hill, New York, 1971.
5. Stepanoff, A.J. "Centrifugal and Axial Flow Pumps," John Wiley and Sons, New York, 1948.
6. Tucker, L.S. "Hydraulics of a Pressurized Sewerage System and Use of Centrifugal Pumps," TM-6, American Society of Civil Engineers, 1967.
7. Tucker, L.S. "Sewage Flow Variations in Individual Homes," TM-2, American Society of Civil Engineers, February 1967.
8. Waller, D.H. "Peak Flow of Sewage from Individual Homes," TM-9, American Society of Civil Engineers, January 1968.

# TYPICAL INDOOR INSTALLATION

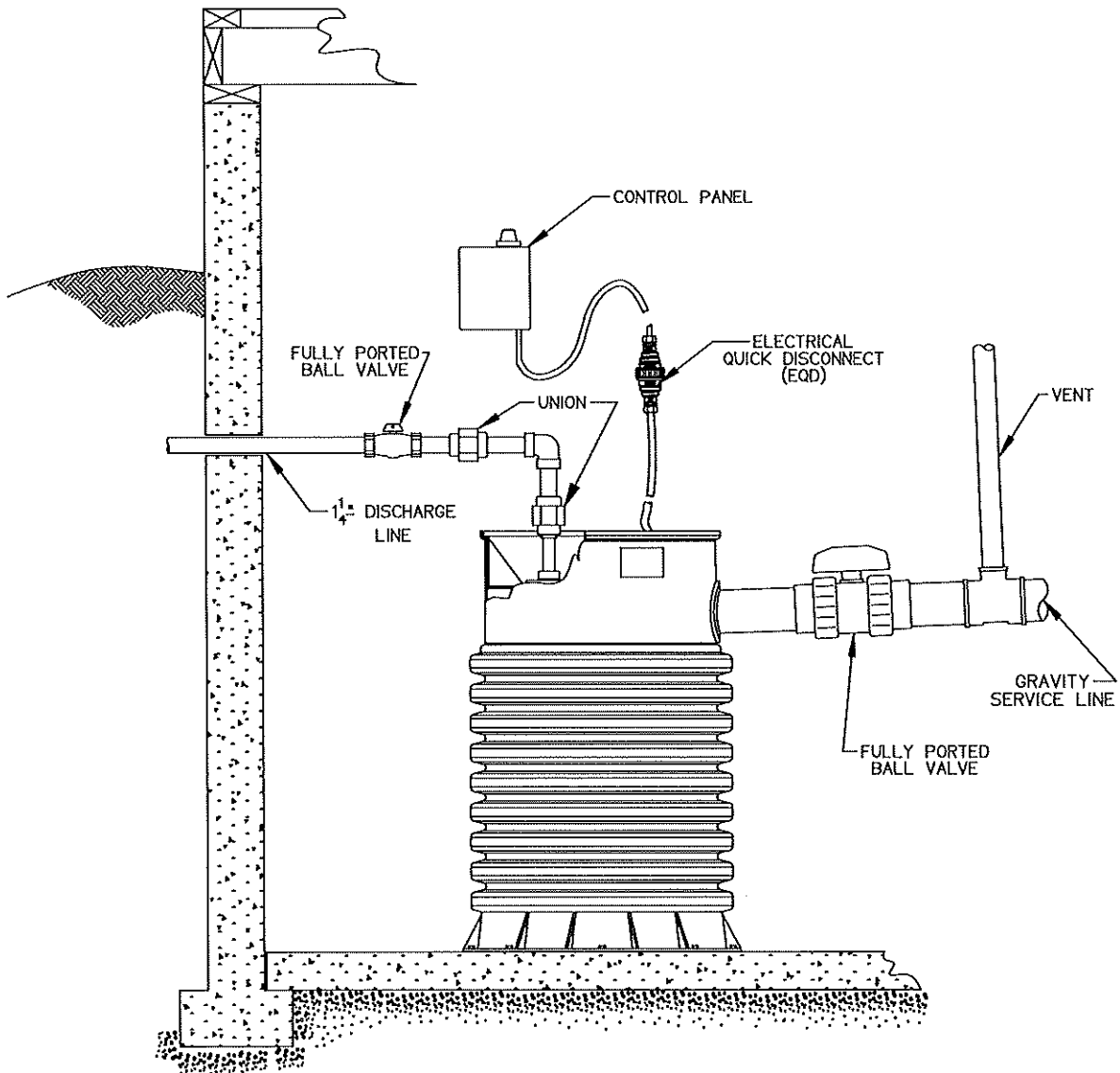

# TYPICAL OUTDOOR INSTALLATION

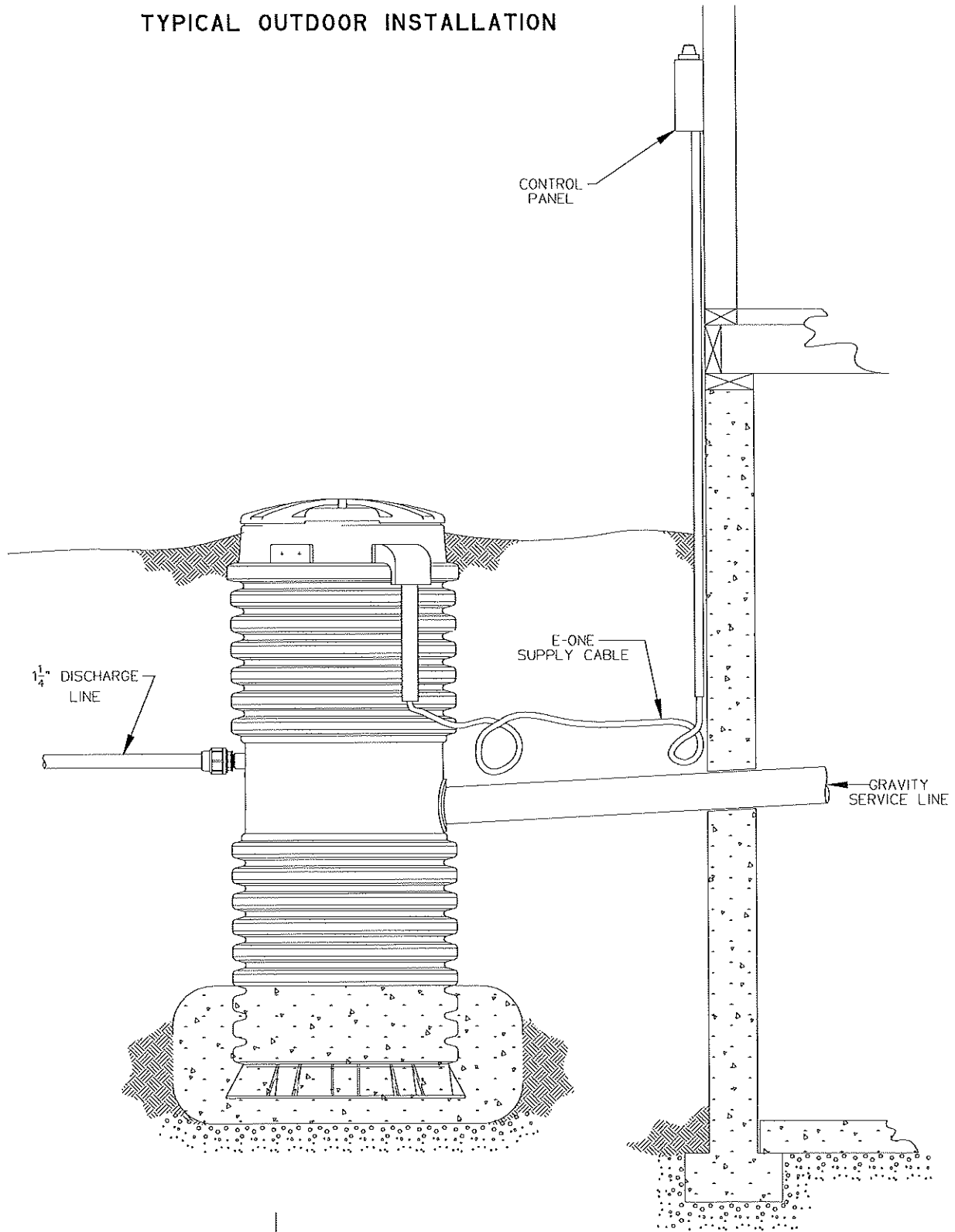

environment|one  
CORPORATION

LM000112 REV. A

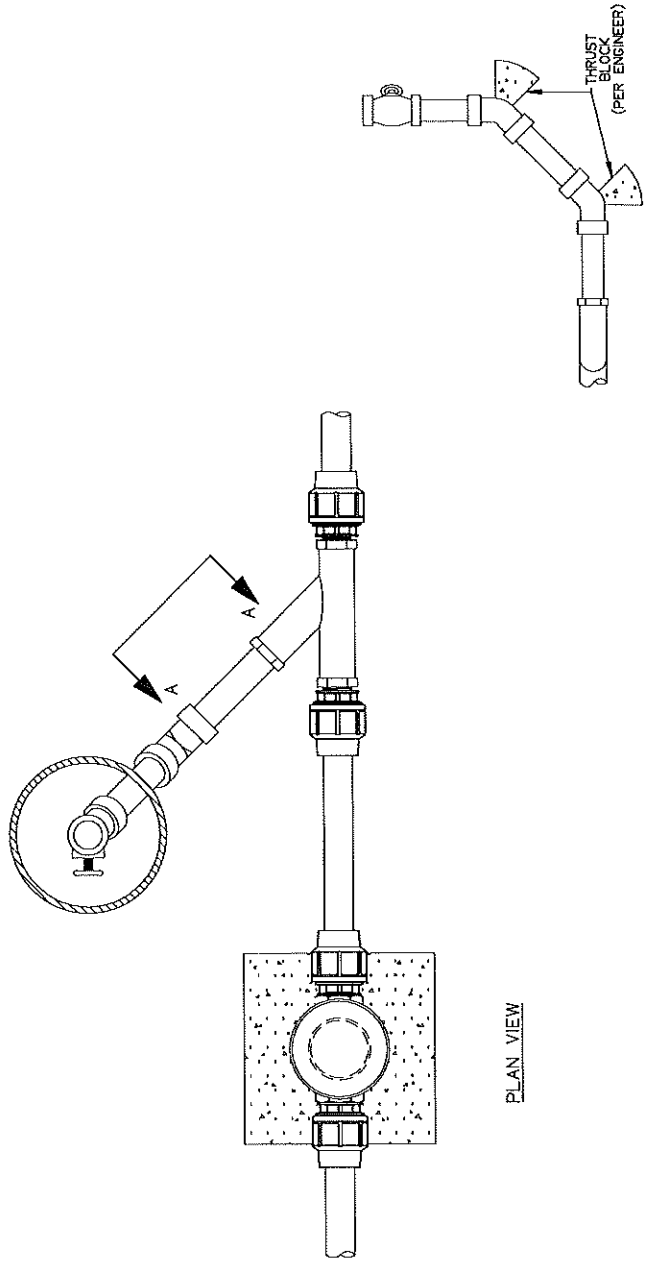

PLAN VIEW

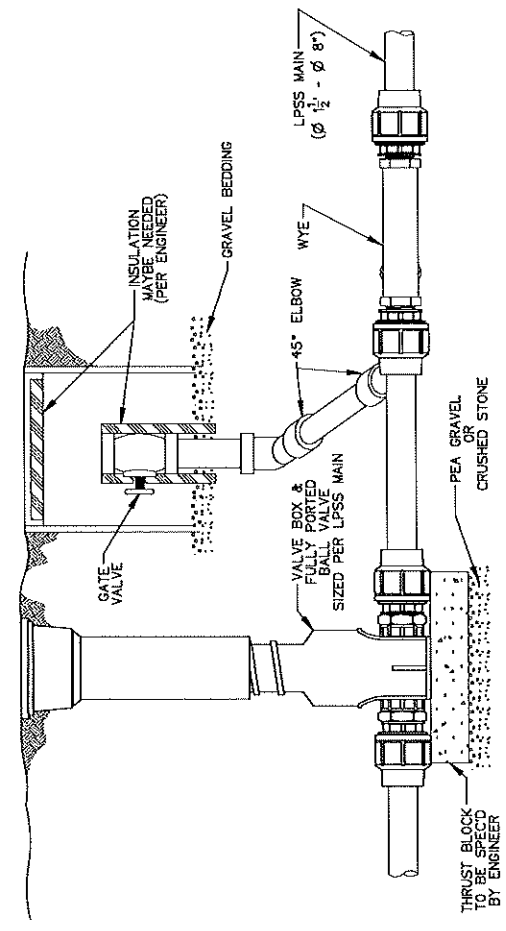

TYPICAL FLUSHING CONNECTION ON LPSS MAIN

# TYPICAL LATERAL INSTALLATION

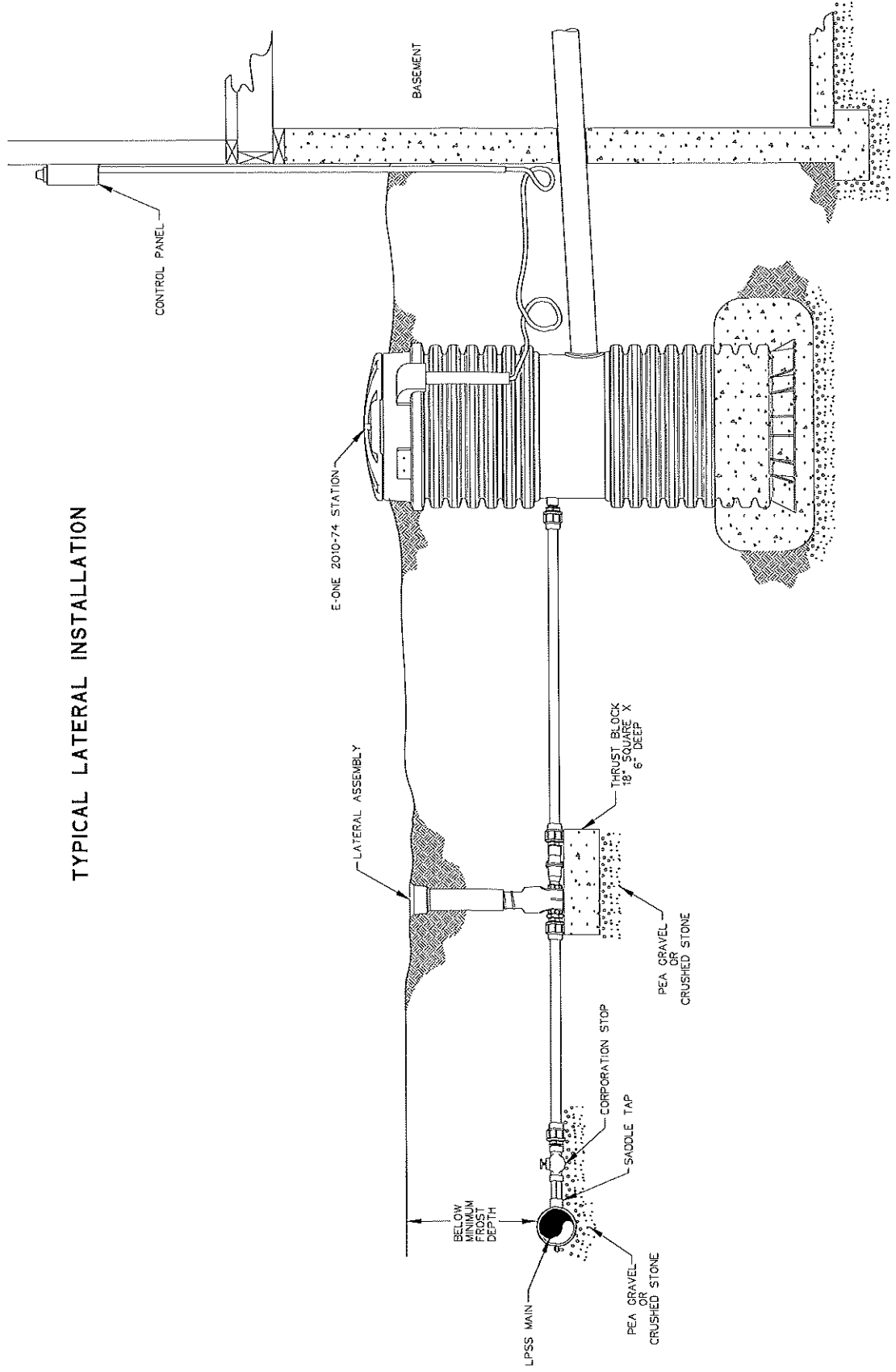

TYPICAL DROP CONNECTION  
LPSS IN EXISTING MANHOLE

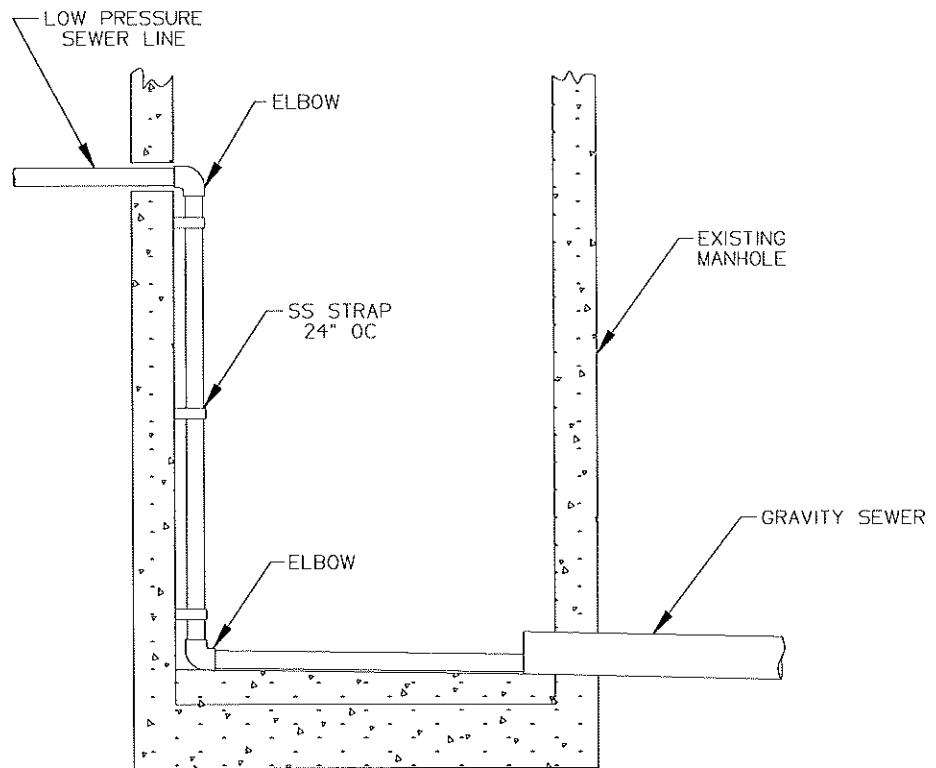



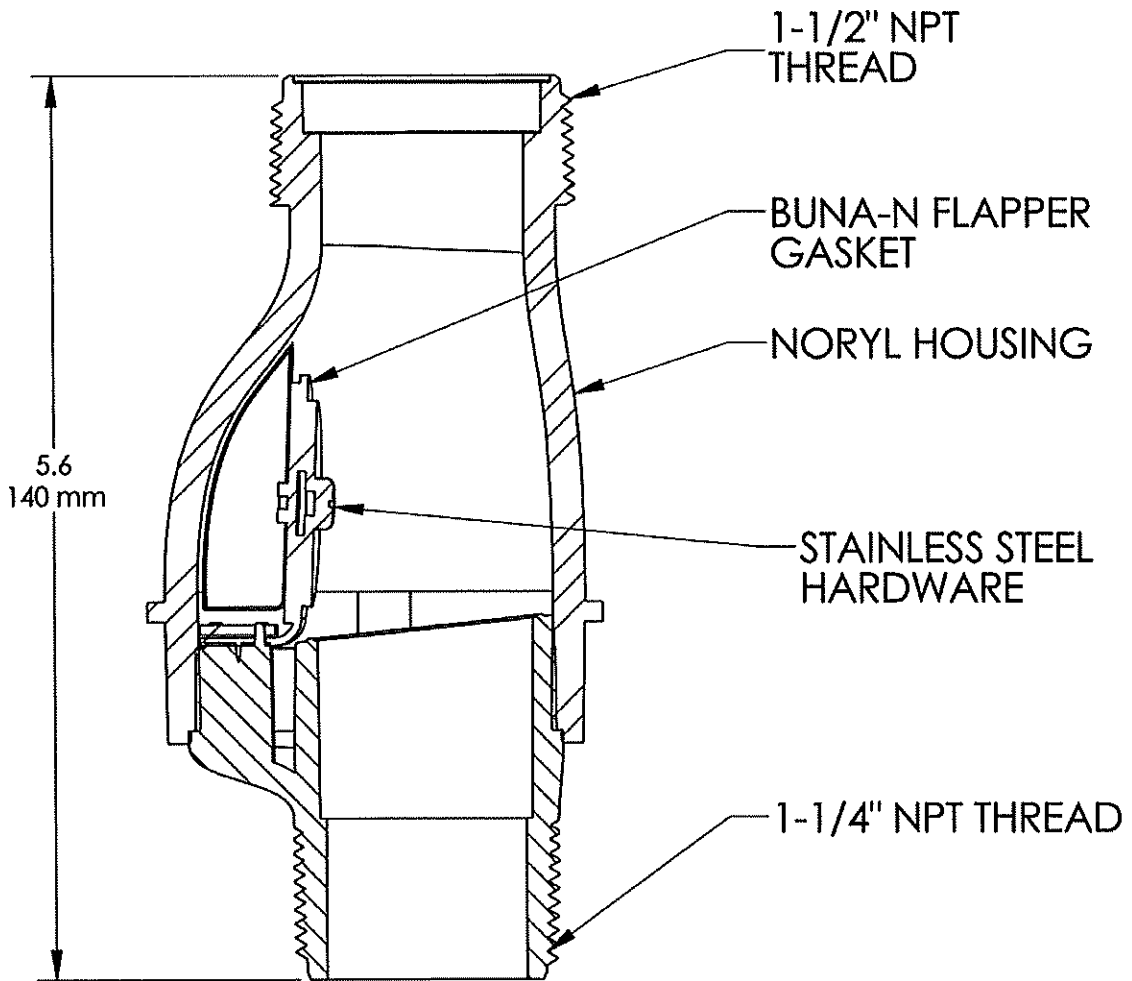

<b>e one</b>	
ENVIRONMENT ONE CORPORATION	
<b>REDUNDANT CHECK VALVE</b>	
ENG MODEL: US Assembly K7	SERVICE #:
DRAWING NUMBER	SH 1 OF 1

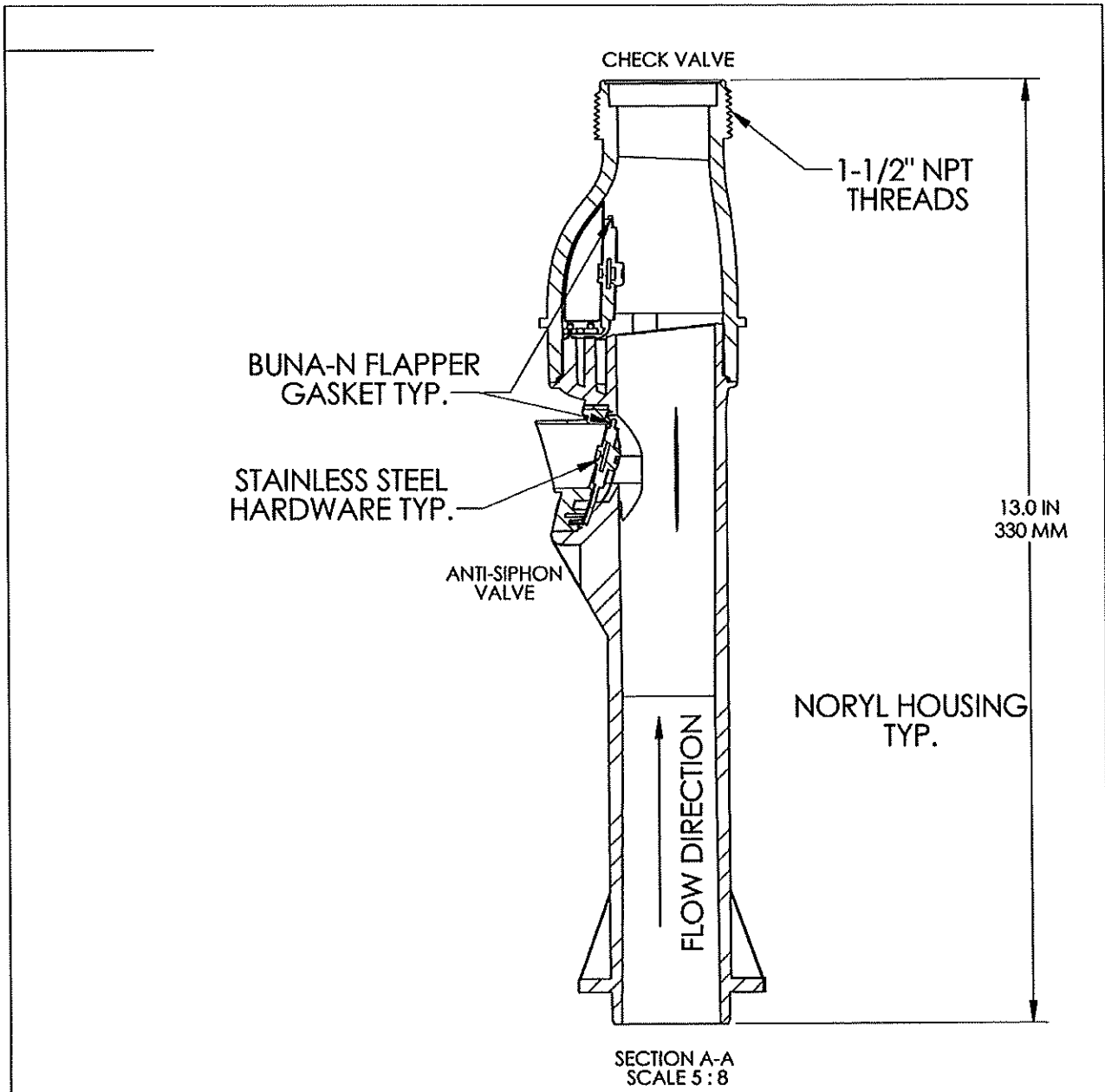

<b>e one</b>	
ENVIRONMENT ONE CORPORATION	
<b>ANTI-SIPHON CHECK VALVE</b>	
SERVICE #	
DRAWING NUMBER	SH 1 OF 1

# Manufacturer Evaluation List

---

	<b>General Requirements for Low Pressure Sewer Systems</b>
<b>Service and Maintenance Check List</b>	<ul style="list-style-type: none"><li>• Local fast-response service and maintenance organization has been designated</li><li>• Manufacturers of all equipment specified for the system have supplied all installation details</li><li>• Warranties for all equipment specified for the system have been evaluated</li><li>• Fast replacement parts availability for all equipment in the system has been ensured by each equipment manufacturer</li><li>• User instructions have been supplied to homeowners</li></ul>
<b>Grinder Pump</b>	<ul style="list-style-type: none"><li>• Designated for the specific purpose of grinding and pumping domestic wastewater</li><li>• Suitable for parallel operation in a system containing thousands of pumps connected to a common discharge line</li><li>• Has a history of reliable operation</li><li>• Compatible with existing power sources and provides economical operation</li><li>• Simple to service and troubleshoot, easily accessible for removal of grinder pump core; designed with simple wiring and controls; easily disassembled and reassembled</li><li>• Warranty covering parts and labor for a reasonable length of time</li><li>• Supported by a thoroughly detailed installation manual, service manual and facilities for service training</li></ul>
<b>Certifications</b>	<ul style="list-style-type: none"><li>• Canadian Standards Association</li><li>• Underwriters Laboratories, Inc.</li><li>• National Sanitation Foundation</li></ul>
<b>Required Features</b>	<ul style="list-style-type: none"><li>• Non-clogging pump</li><li>• Non-jamming grinder</li><li>• Anti-siphon valve integral with grinder pump</li><li>• All valves of non-clogging design: integral check valve, anti-siphon valve and redundant check valve</li><li>• High-level warning alarm</li></ul>
<b>Motor</b>	<ul style="list-style-type: none"><li>• Low rpm (1,725)</li><li>• Overload protection, built-in, automatic reset</li><li>• High torque, low starting current</li></ul>
<b>Tank</b>	<ul style="list-style-type: none"><li>• Self scouring</li><li>• Completely sealed</li><li>• Non-corroding material</li></ul>
<b>Level Sensing Control</b>	<ul style="list-style-type: none"><li>• Non-fouling type</li><li>• No moving parts in contact with sewage</li></ul>
<b>Motor Controls</b>	<ul style="list-style-type: none"><li>• Completely protected</li><li>• Simple to service or replace</li><li>• UL-listed alarm panel</li></ul>



*A Precision Castparts Company*

---

Environment One Corporation  
2773 Balltown Road  
Niskayuna, New York USA 12309-1090

Voice: (01) 518.346.6161  
Fax: 518.346.6188

[www.eone.com](http://www.eone.com)

LM000353 Rev. A  
060208

# WH483/WR483

## General Features

The model WH483 or WR483 grinder pump station is a complete unit that includes: three grinder pumps, check valve, polyethylene tank, controls, and alarm panel. Designed for higher flow applications where local codes dictate higher storage requirements. The lower portion of the tank has a smaller diameter, tapered down to a dish-shaped bottom. The large tank access opening easily accommodates installation of the grinder pumps and equipment.

- Rated for flows of 5000 gpd (18,927 lpd)
- 486 gallons (1840 liters) of capacity
- Standard outdoor heights range from 75 inches to 122 inches

The WH483 is the "hardwired," or "wired," model where a cable connects the motor controls to the level controls through watertight penetrations.

The WR483 is the "radio frequency identification" (RFID), or "wireless," model that uses wireless technology to communicate between the level controls and the motor controls.

## Operational Information

### *Motor*

1 hp, 1,725 rpm, high torque, capacitor start, thermally protected, 120/240V, 60 Hz, 1 phase

### *Inlet Connections*

4-inch inlet grommet standard for DWV pipe. Other inlet configurations available from the factory.

### *Discharge Connections*

Pump discharge terminates in 1.25-inch NPT female thread. Can easily be adapted to 1.25-inch PVC pipe or any other material required by local codes.

### *Discharge*

15 gpm at 0 psig (0.95 lps at 0 m)  
11 gpm at 40 psig (0.69 lps at 28 m)  
7.8 gpm at 80 psig (0.49 lps at 56 m)

## Accessories

E/One requires that the Uni-Lateral, E/One's own stainless steel check valve, be installed between the grinder pump station and the street main for added protection against backflow.

Alarm panels are available with a variety of options, from basic monitoring to advanced notice of service requirements.

The Remote Sentry is ideal for installations where the alarm panel may be hidden from view.

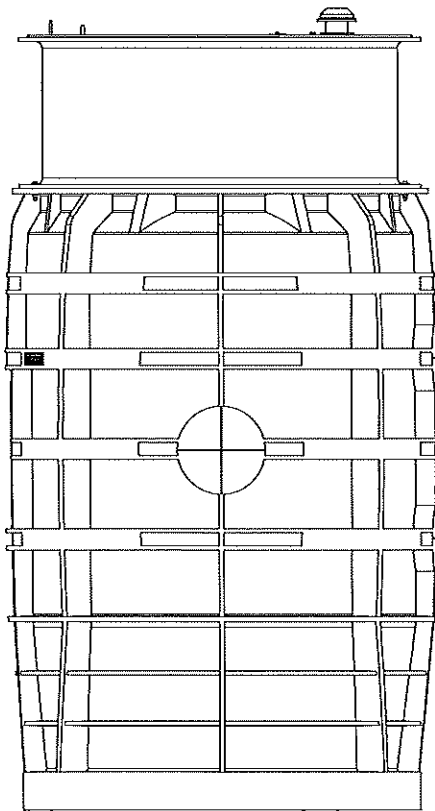

STATION USES 1 DUPLEX MOD T260  
ALARM PANEL AND 1 SIMPLEX SENTRY  
ALARM PANEL

**WH483** (HARD WIRED  
LEVEL CONTROLS)  
 **WR483** (WIRELESS  
LEVEL CONTROLS)

COMBINATION CHECK  
VALVE / ANTI-SIPHON  
VALVE FLAPPER TYPE  
(NORYL)

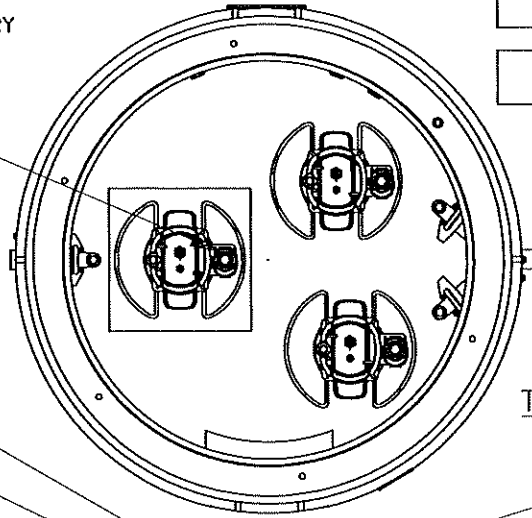

TOP VIEW W/LID NOT SHOWN

E/ONE EQUALIZER

1/3-2/3 SPLIT COVER  
W/HANDLE &  
PADLOCK STAPLE  
(ALUMINUM)

ELECTRICAL QUICK  
DISCONNECT (EQD)  
NEMA 6P

POLYETHYLENE  
MOLDED TANK  
486 GAL (1840 L)

QUICK DISCONNECT  
ASSEMBLY,  
PVC SLIDE FACE

DISCHARGE FTG  
1-1/4" FEMALE  
NPT, SS (X2)

MUSHROOM VENT

TANK ACCESSWAY SECTION  
(FIBERGLASS)

POWER/ALARM CABLE  
(6 CONDUCTOR)  
DIRECT BURY

CABLE CONNECTOR

BULKHEAD FITTING

NYLON LIFTING HARNESS

DISCHARGE WYE MANIFOLD  
(SS) (X2)

INLET, EPDM GROMMET  
TO ACCEPT 4.50" (114 mm)  
O.D. PVC PIPE (STANDARD).  
DUST COVER SUPPLIED  
FOR SHIPMENT (NOT  
SUITABLE FOR BURIAL)

1-1/4" (32 mm) FLEXIBLE  
DISCHARGE HOSE

25.84"  
(656 mm)  
175 gal  
(662 L)  
17.84"  
(453 mm)  
117 gal  
(443 L)  
13.84"  
(352 mm)  
89 gal  
(337 L)

ALARM

ON

OFF

BACK-UP PUMP, ON A 4" (102 mm)  
PEDESTAL (PROVIDED BY OTHERS)

SEMI-POSITIVE DISPLACEMENT TYPE PUMP  
DIRECTLY DRIVEN BY A 1 HP MOTOR

CONCRETE BALLAST MAY BE REQUIRED  
SEE INSTALLATION INSTRUCTIONS  
FOR DETAILS

NOTE: DIMENSIONS ARE FOR REFERENCE ONLY



SGS	PD	12/28/10	B	1/16
DR BY	CHK'D	DATE	ISSUE	SCALE



MODEL WH483 / WR483  
DETAIL SHEET, TRIPLEX

NA0214P02

**WH483-75**

(HARD WIRED  
LEVEL CONTROLS)

**WR483-75**

(WIRELESS  
LEVEL CONTROLS)

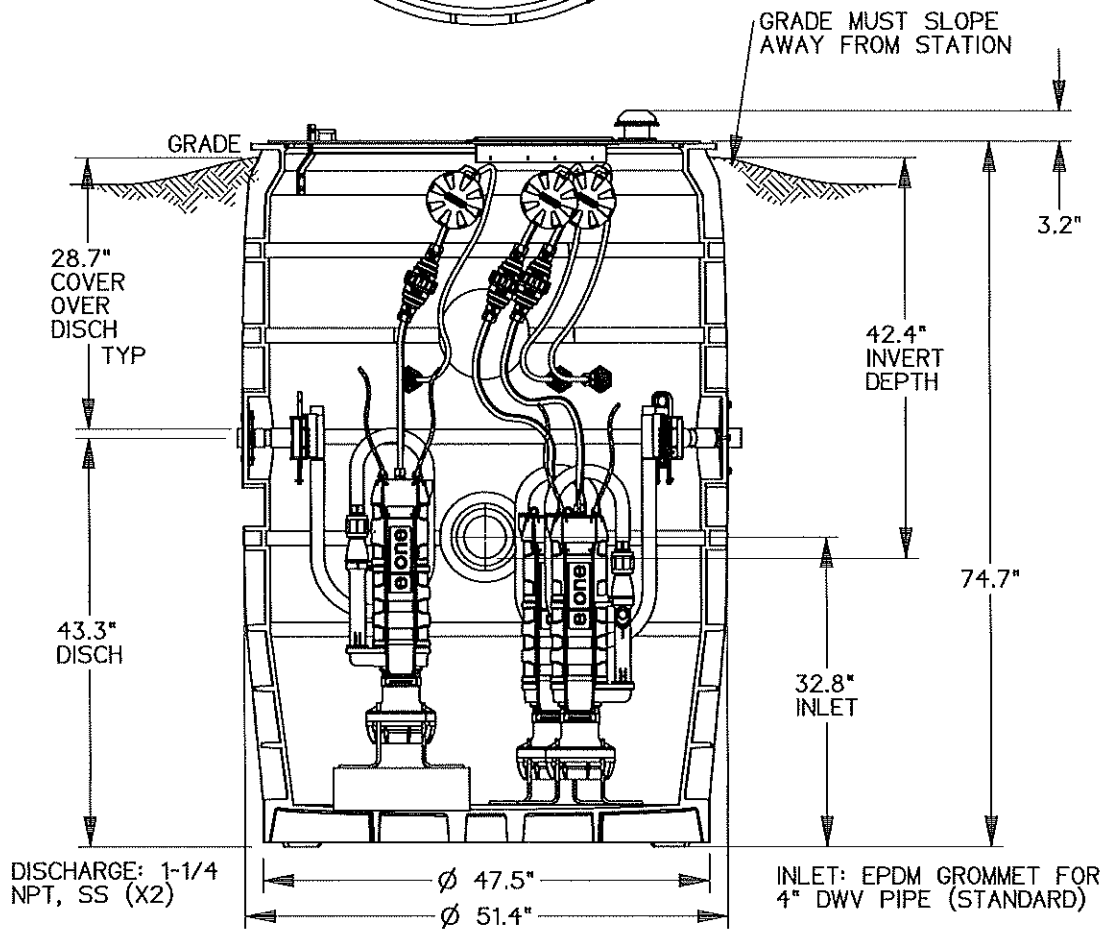
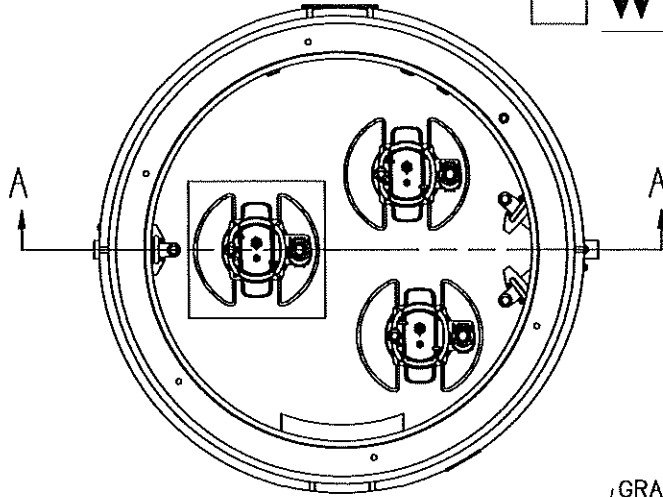

CONCRETE BALLAST MAY BE REQUIRED  
SEE INSTALLATION INSTRUCTIONS  
FOR DETAILS

NOTE: DIMENSIONS ARE FOR REFERENCE ONLY

SGS	PD	06/24/10	A	1/16
DR BY	CHK'D	DATE	ISSUE	SCALE



MODEL WH483-75 / WR483-75

NA0214P03



**WH483-92** (HARD WIRED LEVEL CONTROLS)  
 **WR483-92** (WIRELESS LEVEL CONTROLS)

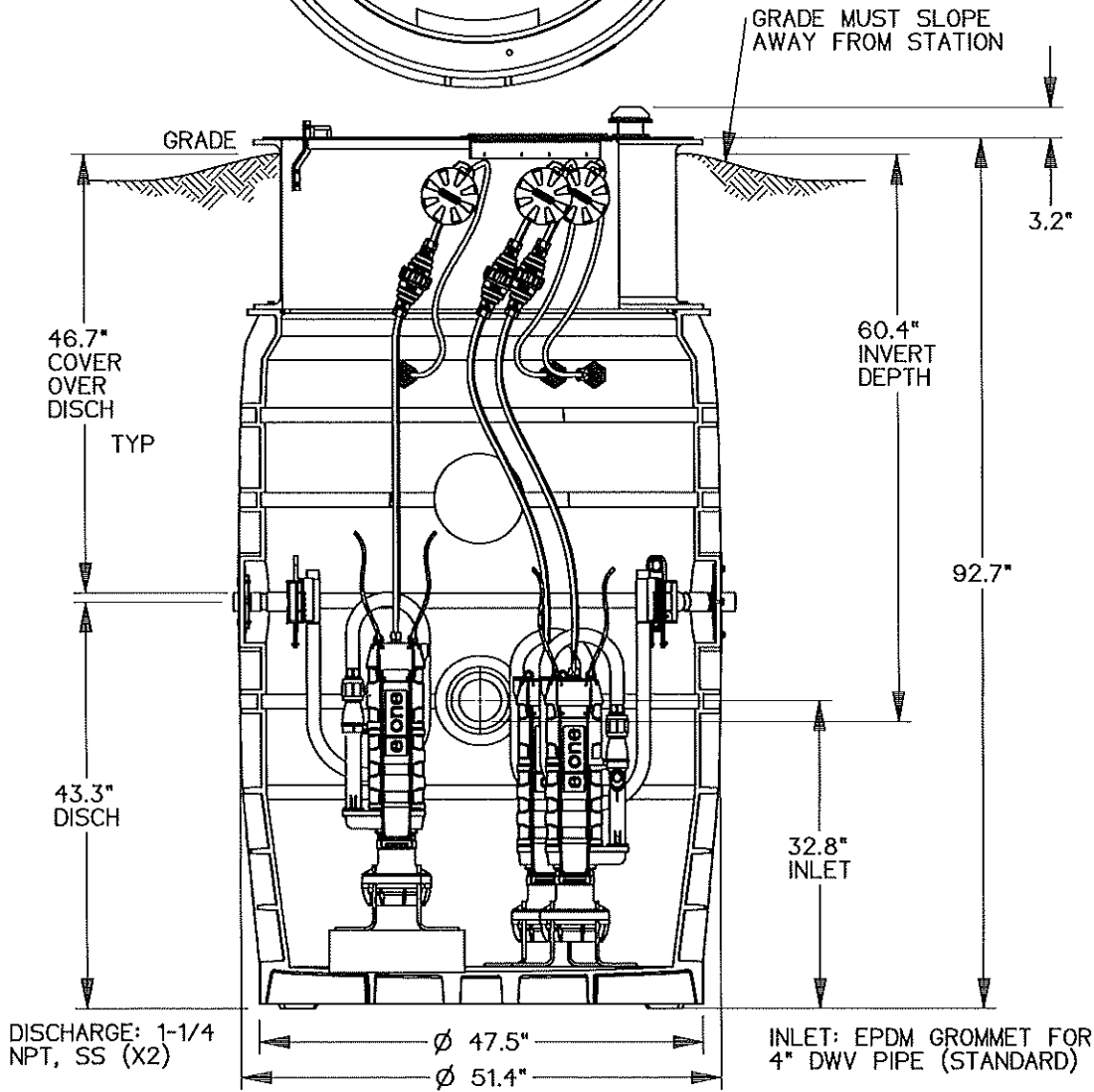
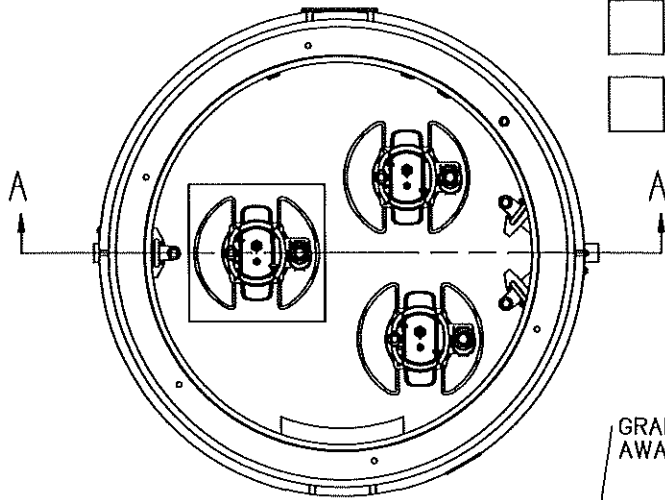

CONCRETE BALLAST MAY BE REQUIRED  
 SEE INSTALLATION INSTRUCTIONS  
 FOR DETAILS

NOTE: DIMENSIONS ARE FOR REFERENCE ONLY

SGS	PD	02/10/11	A	1/16
DR BY	CHK'D	DATE	ISSUE	SCALE



MODEL WH483-92 / WR483-92

NA0214P04





**WH483-122** (HARD WIRED LEVEL CONTROLS)  
 **WR483-122** (WIRELESS LEVEL CONTROLS)

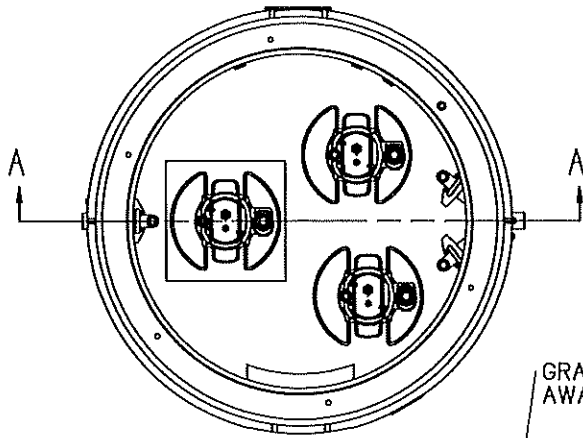

GRADE MUST SLOPE AWAY FROM STATION

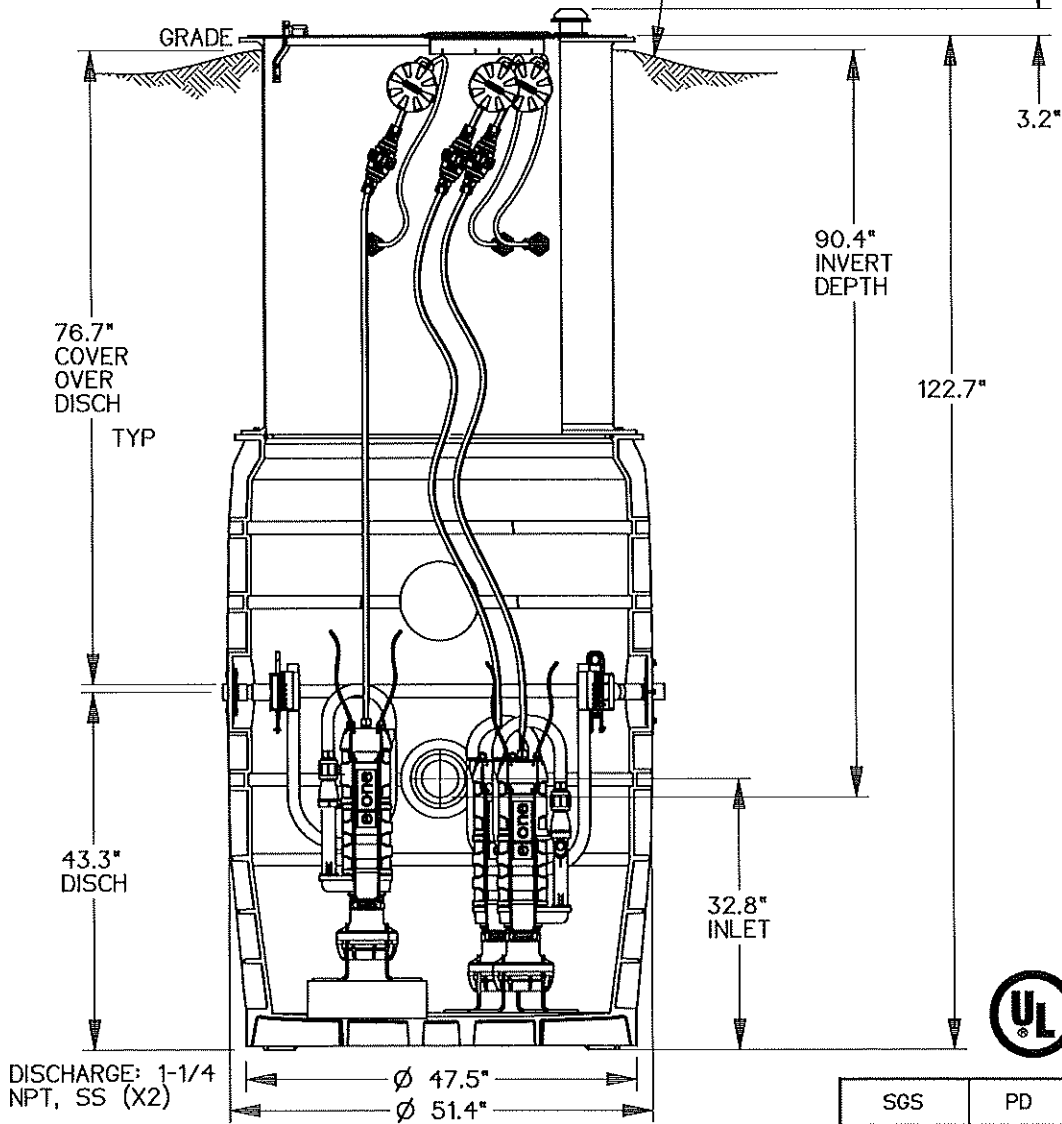

DISCHARGE: 1-1/4 NPT, SS (X2)

Ø 47.5"  
Ø 51.4"

INLET: EPDM GROMMET FOR 4" DWV PIPE (STANDARD)

CONCRETE BALLAST MAY BE REQUIRED  
SEE INSTALLATION INSTRUCTIONS  
FOR DETAILS

NOTE: DIMENSIONS ARE FOR REFERENCE ONLY

SGS	PD	02/10/11	A	1/16
DR BY	CHK'D	DATE	ISSUE	SCALE



MODEL WH483-122 / WR483-122

NA0214P05

**EXHIBIT "C"**

**CT ECO – Environmental Conditions Online**

**Erosion Susceptibility Map**

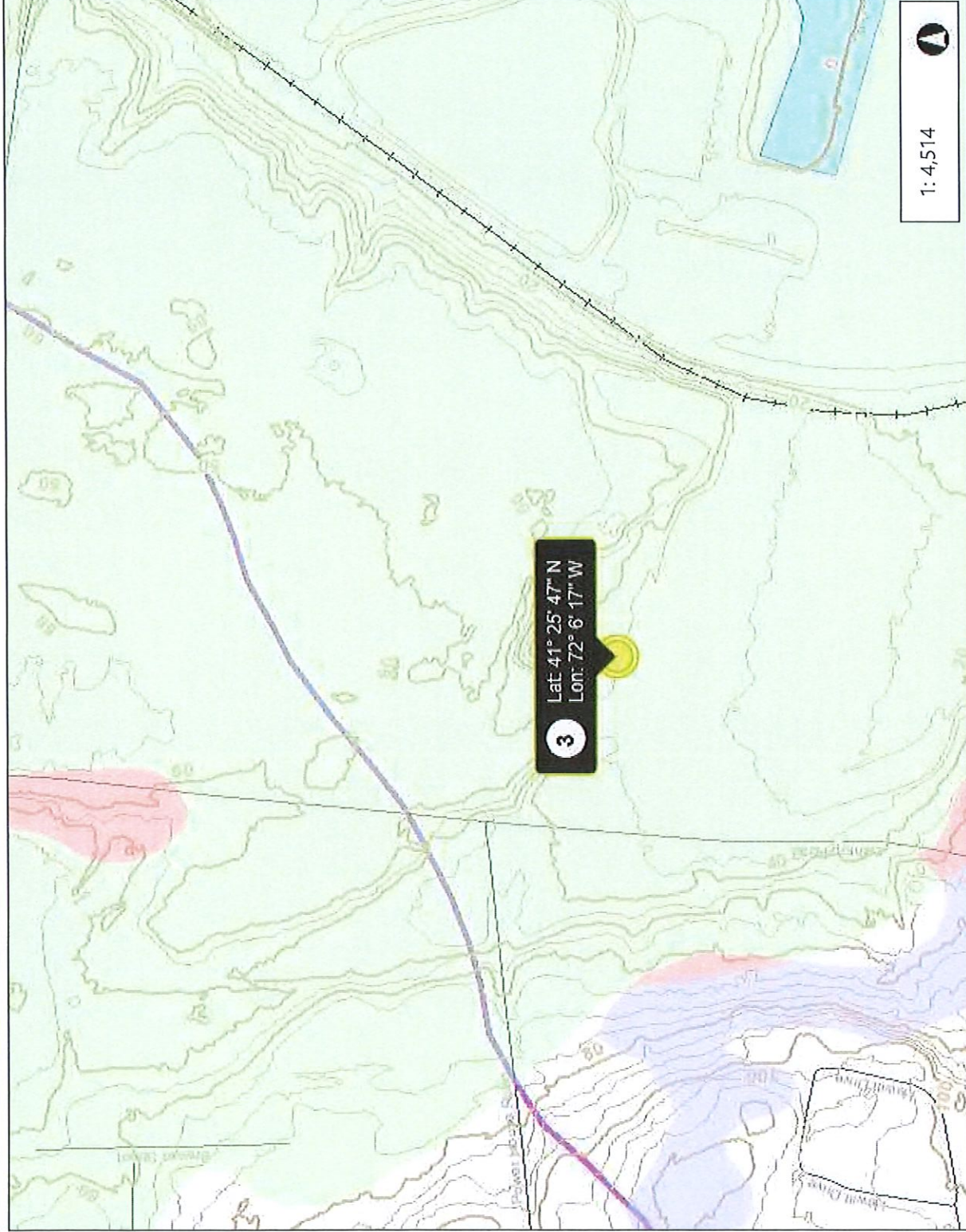

1:4,514

0.1 Miles

0.07

0

0.1

This map is intended for general planning, management, education, and research purposes only. Data shown on this map may not be complete or current. The data shown may have been compiled at different times and at different map scales, which may not match the scale at which the data is shown on this map.

THIS MAP IS NOT TO BE USED FOR NAVIGATION

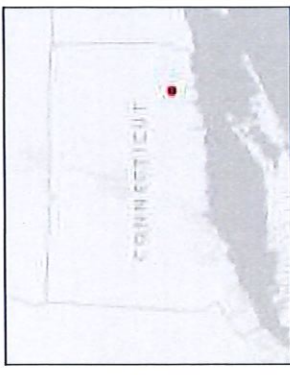

## Legend

### Basin Line

- Major Basin
- Regional Basin
- Subregional Basin
- Local Basin
- Basin Reach

### Erosion Susceptibility

- Most Susceptible to Erosion
- Highly Susceptible to Erosion
- Surficial Materials Susceptible to E
- Soils Susceptible to Erosion

### Geographic Names7

### Geographic Place 3

### Airport

- Airport
- Heliport

### Railroad

+

### Streets

- Interstate Highway
- US Highway
- State Highway
- Primary limited-access
- Ramp
- Street
- Ferry crossing

### County Line

## Notes

**EXHIBIT “D”**

**CT ECO – Environmental Conditions Online**

**Soil Parent Material Map**

**(Probable Underlying Soil Type)**

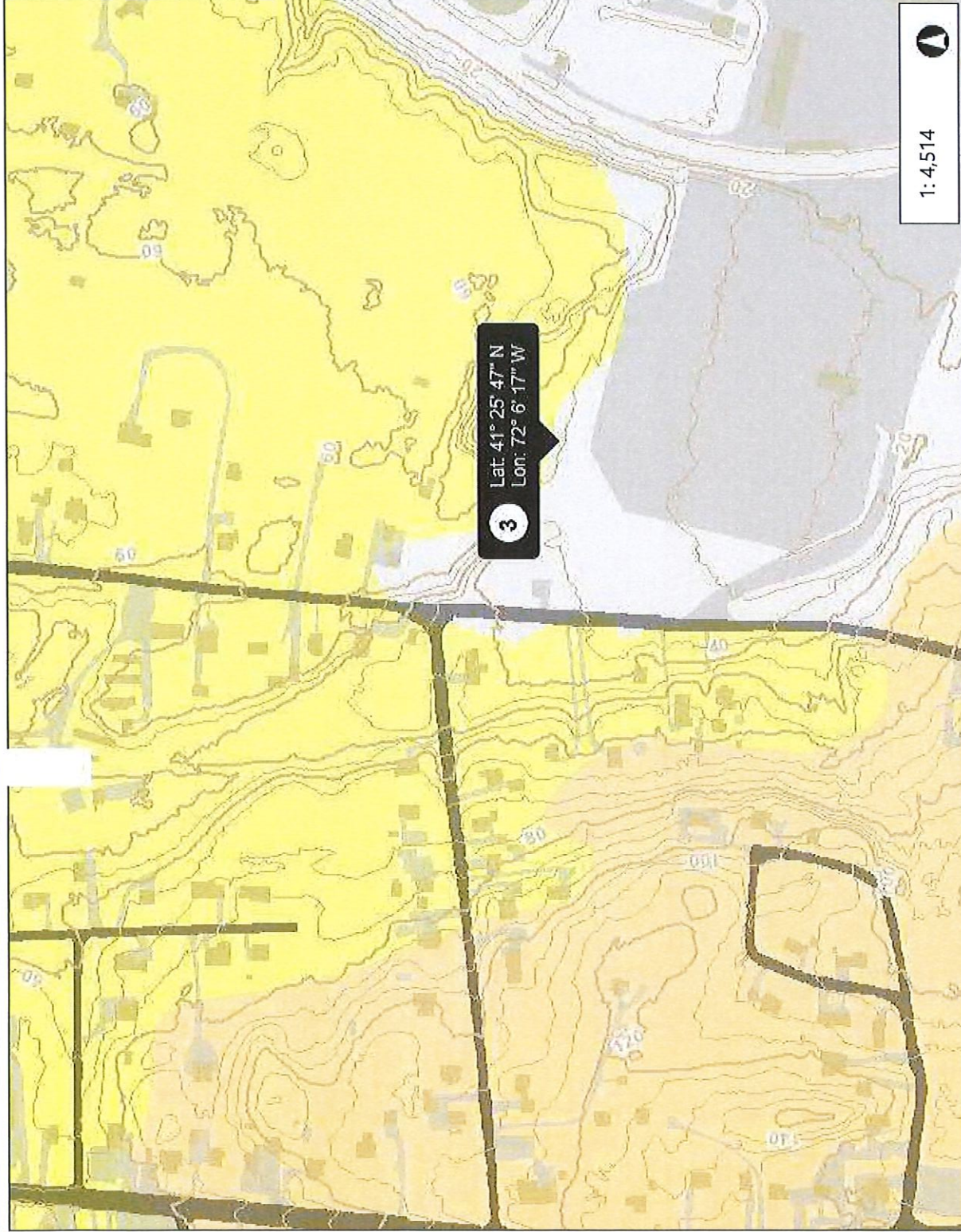

1:4,514

0.1 Miles

0.07

0

0.1

This map is intended for general planning, management, education, and research purposes only. Data shown on this map may not be complete or current. The data shown may have been compiled at different times and at different map scales, which may not match the scale at which the data is shown on this map.



Legend

Impervious Cover 2012

- Not Impervious
- Buildings
- Roads
- Other Impervious

Soil Parent Material

- Moderate to Bedrock
- Moderate - Shallow to Bedrock
- Shallow to Bedrock
- Glaciofluvial - Shallow to Bedrock
- Glaciofluvial
- Melt-out Till
- Melt-out Till - Moderate to Bedrock
- Melt-out Till - Shallow to Bedrock
- Deep Organic - Inland
- Shallow Organic - Inland
- Deep Organic - Tidal
- Shallow Organic - Tidal
- Alluvial/Floodplain
- Glaciolacustrine
- Lodgement Till
- Urban Influenced

Geographic Names7

Geographic Place 3

Airport

- Airport

Notes

**EXHIBIT “E”**

**FEMA – Federal Emergency Management Agency**

**FIRM – Insurance Rate Map**

