

TOWN OF MONTVILLE, CONNECTICUT

CONTRACT DRAWINGS FOR

COOK HILL TANK REPLACEMENT PROJECT

MONTVILLE WATER SUPPLY

AUGUST 2022
PERMITTING REVIEW

DRAWING INDEX

GENERAL

--- COVER

CIVIL

C-1 GENERAL NOTES, LEGEND, ABBREVIATIONS, AND DETAILS
 C-2 DEMOLITION PLAN AND OVERALL MODIFICATIONS
 C-3 SITE PIPING, LAYOUT AND GRADING PLANS
 C-4 EROSION CONTROL NOTES AND DETAILS
 C-5 CIVIL DETAILS

SURVEY

--- SURVEY

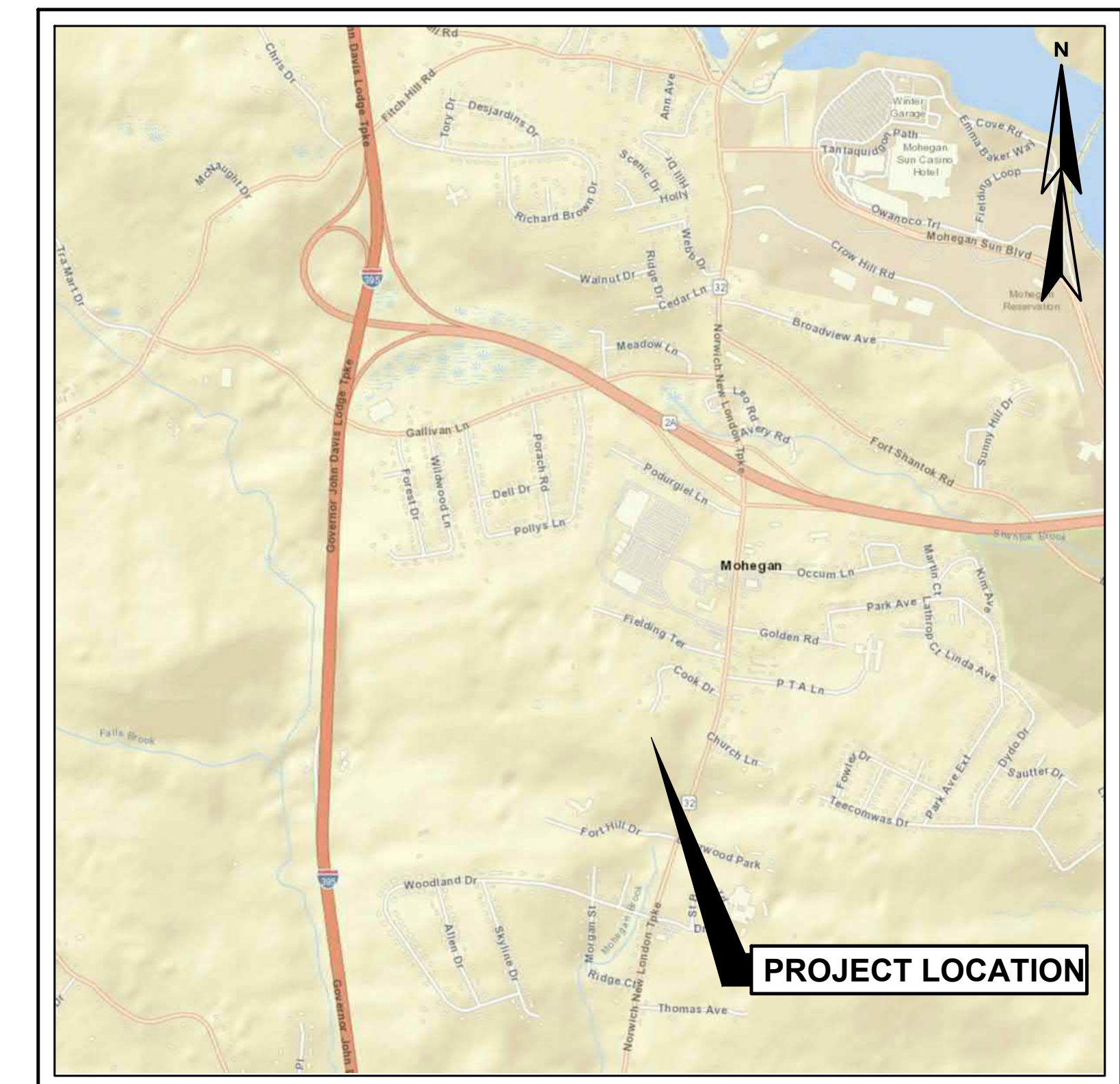
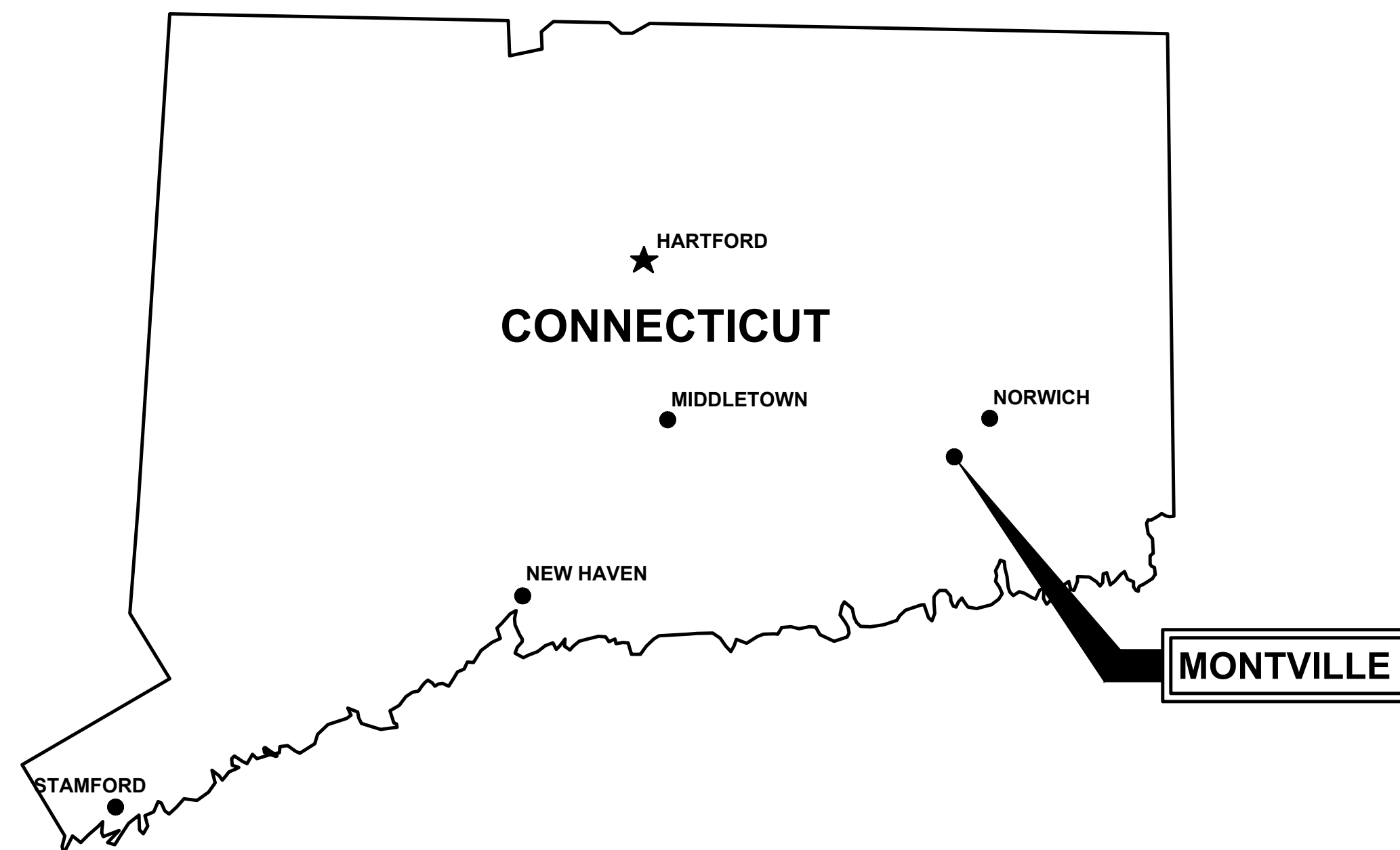

LOCATION PLAN
SCALE: 1"=2,000'

ZONING INFORMATION

ZONE R-20
FRONT AND REAR SETBACKS- 40FT.
SIDE SETBACKS- 20FT.

CONTACT INFORMATION

APPLICANT
 NAME: RON MCDANIEL C/O MONTVILLE WPCA
 PHONE: (860) 848-6776
 ADDRESS: 83 PINK ROW, UNCASVILLE, CT 06382

OWNER OF RECORD

NAME: TOWN OF MONTVILLE
 PHONE: (860) 848-3030
 ADDRESS: 310 NORWICH-NEW LONDON TPKE., UNCASVILLE, CT 06382

WRIGHT-PIERCE 
Engineering a Better Environment

860.343.8297 | www.wright-pierce.com



"APPROVED BY THE TOWN OF MONTVILLE PLANNING AND ZONING COMMISSION"

SIGNATURE OF CHAIRMAN OR SECRETARY

DATE

WP PROJECT No. 20410B

GENERAL NOTES

- 1. THE OWNER WILL BE RESPONSIBLE FOR OBTAINING THE PERMITS LISTED IN THE SUPPLEMENTARY OR SPECIAL CONDITIONS. IT IS THE RESPONSIBILITY OF THE CONTRACTOR TO BE FAMILIAR WITH THE APPLICABLE PROVISIONS OF EACH PERMIT AS THEY APPLY TO THE WORK PRIOR TO BIDDING AND ABIDE BY THOSE PROVISIONS DURING CONSTRUCTION. COPIES OF ALL OBTAINED PERMITS ARE AVAILABLE FOR REVIEW FROM THE OWNER. ALL OTHER PERMITS ARE THE RESPONSIBILITY OF THE CONTRACTOR.
2. THE OWNER SHALL BE RESPONSIBLE FOR OBTAINING ALL NECESSARY RIGHTS-OF-WAY AND EASEMENTS. THE CONTRACTOR SHALL VERIFY THAT THE NECESSARY EASEMENTS HAVE BEEN SECURED BY THE OWNER. IT IS THE RESPONSIBILITY OF THE CONTRACTOR TO BE FAMILIAR WITH THE APPLICABLE PROVISIONS OF EACH EASEMENT AS THEY APPLY TO THE WORK PRIOR TO BIDDING AND ABIDE BY THOSE PROVISIONS DURING CONSTRUCTION. COPIES OF ALL RIGHTS-OF-WAY AND EASEMENTS ARE AVAILABLE FOR REVIEW FROM THE OWNER.
3. THE CONTRACTOR IS RESPONSIBLE FOR MAINTAINING TRAFFIC FLOW AT ALL TIMES. CONTRACTOR SHALL INSTALL AND MAINTAIN TRAFFIC CONTROL SIGNS IN ACCORDANCE WITH THE MUTCD AND ALL STATE AND LOCAL REGULATIONS. THE CONTRACTOR IS REQUIRED TO SUBMIT A TRAFFIC CONTROL PLAN TO THE OWNER PRIOR TO COMMENCING CONSTRUCTION. THE POLICE DEPARTMENT AND FIRE DEPARTMENT ARE TO BE NOTIFIED AT LEAST 24-HOURS IN ADVANCE OF ANY STREET CLOSING OR DETOUR. REFER TO SPECIFICATION SECTION 01570.
4. CONTRACTOR SHALL COMPLY WITH ALL APPLICABLE REGULATIONS OF THE OCCUPATIONAL SAFETY AND HEALTH ADMINISTRATION (OSHA).
5. CONTRACTOR SHALL COMPLY WITH THE COORDINATION REQUIREMENTS AND RELATED COSTS, IF ANY, AS SPECIFIED IN SPECIFICATION SECTION 01050.
6. CONTRACTOR SHALL NOTE THAT, IN GENERAL, ALL EXISTING CONDITION INFORMATION ON THE DRAWINGS ARE SHOWN WITH A LIGHTER LINE WEIGHT AND WITH A SLANTED TYPE TEXT.
7. ALL EXISTING WATER AND STORM DRAIN LINES ENCOUNTERED DURING CONSTRUCTION ARE TO REMAIN IN SERVICE. ANY EXISTING WATER MAINS, STORM DRAIN LINES OR CULVERTS DAMAGED DURING CONSTRUCTION SHALL BE REPAIRED BY THE CONTRACTOR AT NO ADDITIONAL COST TO THE OWNER.
8. ALL STRUCTURES AND PIPELINES LOCATED ADJACENT TO TRENCH EXCAVATION SHALL BE PROTECTED AND FIRMLY SUPPORTED BY THE CONTRACTOR UNTIL THE TRENCH IS BACKFILLED. INJURY TO ANY SUCH STRUCTURES CAUSED BY OR RESULTING FROM THE CONTRACTOR'S OPERATIONS SHALL BE REPAIRED AT THE CONTRACTOR'S EXPENSE. ALL UTILITIES REQUIRING REPAIR, RELOCATION OR ADJUSTMENT AS A RESULT OF THE PROJECT SHALL BE COORDINATED THROUGH THE RESPECTIVE UTILITY.
9. IN THOSE INSTANCES WHERE POWER OR TELEPHONE POLE SUPPORT IS REQUIRED, THE CONTRACTOR SHALL PROVIDE A MINIMUM 48-HOUR NOTICE TO THE RESPECTIVE UTILITY POLE OWNER. NO ADDITIONAL PAYMENT WILL BE PROVIDED FOR TEMPORARY BRACING OF UTILITIES.

EXISTING SITE CONDITIONS

- 1. THE LOCATIONS OF UNDERGROUND UTILITIES AND STRUCTURES, AS SHOWN ON THE DRAWINGS, ARE APPROXIMATE AND MAY NOT BE COMPLETE. NO GUARANTEE IS MADE THAT UTILITIES OR STRUCTURES WILL BE ENCOUNTERED WHERE SHOWN, OR THAT ALL UNDERGROUND UTILITIES AND STRUCTURES ARE SHOWN. ALL LOCATIONS AND SIZES OF EXISTING UTILITIES AND STRUCTURES SHALL BE VERIFIED IN THE FIELD WITH TEST PITS AS REQUIRED PRIOR TO BEGINNING CONSTRUCTION OF NEW FACILITIES OR PIPING THAT MAY BE AFFECTED. THE CONTRACTOR WILL REALIGN NEW PIPE LOCATIONS AS REQUIRED TO CONFORM TO EXISTING LINES AND AS APPROVED BY THE ENGINEER.
2. BELOW GRADE UTILITY INFORMATION IS BASED ON INFORMATION PROVIDED BY EACH UTILITY. LOCATION OF PUBLIC UTILITIES SHOWN IS ONLY APPROXIMATE AND MAY NOT BE COMPLETE. PRIVATE UNDERGROUND UTILITIES SUCH AS, BUT NOT LIMITED TO, SEWER LINES, WATER LINES AND BURIED ELECTRICAL SERVICE ENTRANCES ARE NOT SHOWN. THE CONTRACTOR SHALL ASCERTAIN THE LOCATION AND SIZE OF EXISTING UTILITIES IN THE FIELD WITH THE RESPECTIVE UTILITY COMPANY REPRESENTATIVE PRIOR TO COMMENCING WORK. REFER TO SPECIFICATION SECTION 01050. ADDITIONAL TEST PITS, BEYOND THOSE SHOWN, MAY BE REQUIRED. UTILITY CONTACTS ARE AS FOLLOWS:
WATER: MONTVILLE WATER SUPPLY
ADDRESS: 83 PINK ROW, UNCASVILLE, CT 06382
PHONE: (860) 848-3830
ELECTRIC: EVERSOURCE ENERGY
PHONE: (800) 286-2000
WEBSITE: WWW.EVERSOURCE.COM/CONTENT
DIG SAFE: CALL BEFORE YOU DIG
ADDRESS: 2040 WHITNEY AVENUE HAMDEN, CT 06517
PHONE: 811 OR (800) 432-4770
3. THERE ARE NO KNOWN HAZARDOUS ENVIRONMENTAL CONDITIONS WITHIN THE AREA OF WORK. IF THE PRESENCE OF HAZARDOUS ENVIRONMENTAL CONDITIONS ARE DISCOVERED, THE CONTRACTOR SHALL NOTIFY THE OWNER AND THE ENGINEER IMMEDIATELY. ALL ACTIVITIES, HANDLING AND DISPOSAL OF HAZARDOUS ENVIRONMENTAL CONDITIONS AND MATERIALS SHALL BE IN ACCORDANCE WITH OSHA, FEDERAL, STATE, AND LOCAL REGULATIONS.

SITE DEMOLITION

- 1. REFER TO THE EXISTING SITE PLAN, FOR ADDITIONAL INFORMATION REGARDING EXISTING FACILITIES. REFER TO THE LAYOUT DRAWING FOR LIMITS OF WORK.
2. REFER TO SPECIFICATION SECTION 01010, WHICH CONTAINS INFORMATION ON CONSTRAINTS OF CONSTRUCTION SEQUENCING.
3. DEMOLISH/REMOVE EXISTING PIPING AS REQUIRED FOR CONSTRUCTION OF NEW FACILITIES. ALL PIPING, EQUIPMENT AND MATERIALS TO BE DEMOLISHED AND/OR REMOVED FROM SERVICE SHALL BE COORDINATED WITH THE OWNER AND ENGINEER BEFORE COMMENCING THAT WORK. EXISTING PIPING THAT NEEDS TO BE REMOVED TO CONSTRUCT THE NEW FACILITIES, BUT IS TO REMAIN, SHALL BE REINSTALLED/REPLACED AS NEEDED. EXISTING PIPES AND CONDUIT DESIGNATED AS "ABANDONED" MAY BE REMOVED IF THE CONTRACTOR SO CHOOSES. IF ABANDONED PIPE CONFLICTS WITH NEW SITE PIPING OR FACILITIES, THEN A PORTION OF THE ABANDONED PIPE SHALL BE REMOVED, AND THE NEW ENDS OF ABANDONED PIPE CAPPED OR PLUGGED WITH CONCRETE.
4. SEVERING OF EXISTING UTILITIES FOR ABANDONMENT, OR REMOVAL OF A SEGMENT FROM SERVICE, SHALL BE PERFORMED IN SUCH A MANNER AS TO ALLOW THE REMAINING ACTIVE SEGMENT TO CONTINUE IN ITS INTENDED SERVICE. CAP ACTIVE SEGMENTS WITH APPROPRIATE FITTINGS, JOINT RESTRAINT, ETC. TO ENSURE THEIR INTEGRITY. PLUG ENDS OF ABANDONED PIPE SEGMENTS WITH CONCRETE UNLESS SPECIAL CIRCUMSTANCES DICTATE PLUGGING ABANDONED PIPES WITH BLIND FLANGES, RESTRAINED MECHANICAL JOINT PLUGS, ETC. AS APPROPRIATE.
5. THE CONTRACTOR SHALL BE RESPONSIBLE FOR REMOVING AND DISPOSING OF ALL DEMOLISHED PIPING, EQUIPMENT AND MATERIALS. DISPOSAL SHALL BE IN ACCORDANCE WITH ALL STATE AND LOCAL REGULATIONS. THE OWNER RESERVES THE RIGHT TO RETAIN ANY SUCH PIPING, EQUIPMENT AND MATERIALS DESIGNATED FOR DEMOLITION. SUCH MATERIALS TO BE RETAINED SHALL BE PROPERLY STORED IN AN ON-SITE LOCATION. COORDINATE LOCATION AND MATERIALS TO BE SALVAGED WITH THE OWNER/ENGINEER. REFER TO SPECIFICATION SECTION 02050.
6. THE CONTRACTOR SHALL KEEP A RECORD OF DEMOLITION AS PART OF THE PROJECT RECORD DOCUMENTS IN ACCORDANCE WITH SPECIFICATION SECTION 01720.
7. THE CONTRACTOR SHALL BE RESPONSIBLE FOR THE APPROPRIATE DISPOSAL OF FLOWS RESULTING FROM PRECIPITATION AND GROUNDWATER DEWATERING OPERATIONS.

SITE CLEARING, GRUBBING AND GRADING

- 1. STRIPPING OF TOPSOIL (LOAM) SHALL BE IN ACCORDANCE WITH SPECIFICATION SECTION 02115. REFER TO THE LAYOUT AND GRADING DRAWINGS FOR LIMIT OF WORK AND STRIPPING.
2. CONTRACTOR SHALL MINIMIZE CLEARING OPERATIONS. CLEARING AND GRUBBING SHALL BE IN ACCORDANCE WITH SPECIFICATION SECTION 02110. CLEARING LIMITS SHALL BE AS INDICATED ON THE DRAWINGS, BUT AT ALL TIMES WITHIN EXISTING ROAD RIGHTS-OF-WAY AND PROPERTY LINES ON STATE OR COUNTY OWNED PROPERTY OR EASEMENTS. ALL CLEARING AND GRUBBING MATERIAL SHALL BE THE PROPERTY OF THE CONTRACTOR AND SHALL BE DISPOSED OF AT A SITE PROVIDED BY THE CONTRACTOR IN COMPLIANCE WITH ALL STATE AND LOCAL LAWS.
3. CONTRACTOR SHALL PROVIDE PROPER EROSION CONTROL AND DRAINAGE MEASURES IN ALL AREAS OF WORK, AND CONFINE SOIL SEDIMENT TO WITHIN THE LIMITS OF EXCAVATION AND GRADING. PRIOR TO BEGINNING EXCAVATION WORK, EROSION CONTROL FENCE SHALL BE INSTALLED AT THE DOWN GRADIENT PERIMETER OF THE ACTUAL LIMITS OF GRUBBING AND/OR GRADING. EROSION CONTROL FENCE SHALL ALSO BE INSTALLED AT THE DOWN GRADIENT PERIMETER OF THE TOPSOIL STOCKPILES. ALL DISTURBED EARTH SURFACES SHALL BE STABILIZED IN THE SHORTEST PRACTICAL TIME AND TEMPORARY EROSION CONTROL DEVICES SHALL BE EMPLOYED UNTIL SUCH TIME AS ADEQUATE SOIL STABILIZATION HAS BEEN ACHIEVED. TEMPORARY STORAGE OF EXCAVATED MATERIAL SHALL BE STABILIZED IN A MANNER THAT WILL MINIMIZE EROSION. ALL INSTALLED EROSION CONTROL FACILITIES SHALL BE REMOVED AT THE END OF THE PROJECT. REFER TO SPECIFICATION SECTION 02270.
4. ALL STORM DRAINAGE INLETS SHALL BE PROTECTED BY HAY BALE FILTERS TO PREVENT ENTRY OF SEDIMENT FROM RUNOFF WATERS DURING CONSTRUCTION. CONTRACTOR SHALL BE RESPONSIBLE FOR THE REMOVAL AND DISPOSAL OF ALL COLLECTED SEDIMENT, AND THAT WHICH COLLECTS IN THE STORM DRAIN SYSTEM.
5. CONTRACTOR SHALL CONTROL DUST ON THE CONSTRUCTION SITE TO A REASONABLE LIMIT, AS DETERMINED BY THE ENGINEER, AND AS OUTLINED IN SPECIFICATION SECTION 01562.
6. CONTRACTOR SHALL NOT TRACK OR SPILL EARTH, DEBRIS OR OTHER CONSTRUCTION MATERIAL ON PUBLIC OR PRIVATE STREETS AND PLANT DRIVES. THE CONTRACTOR SHALL BE RESPONSIBLE FOR THE IMMEDIATE ASSOCIATED CLEAN UP.
7. ALL CATCH BASINS, MANHOLES, VALVE PITS, VALVE BOXES AND OTHER BURIED FACILITIES WITH SURFACE ACCESS SHALL BE ADJUSTED TO MATCH FINAL GRADES, UNLESS OTHERWISE INDICATED.
8. THE CONTRACTOR SHALL NOT HAVE ANY RIGHT OF PROPERTY IN ANY MATERIALS TAKEN FROM ANY EXCAVATION. SUITABLE EXCAVATED MATERIAL MAY BE INCORPORATED IN THE PROJECT, WITH EXCESS MATERIAL DISPOSED OF AT A LOCATION PROVIDED BY THE CONTRACTOR. THESE PROVISIONS SHALL IN NO WAY RELIEVE THE CONTRACTOR OF OBLIGATIONS TO PROPERLY DISPOSE OF AND REPLACE ANY MATERIAL DETERMINED BY THE ENGINEER TO BE UNSUITABLE FOR BACKFILLING. THE CONTRACTOR SHALL DISPOSE OF UNSUITABLE AND EXCESS MATERIAL IN ACCORDANCE WITH THE APPLICABLE SECTIONS OF THE CONTRACT DOCUMENTS.
9. CONTRACTOR SHALL REMOVE AND REPLACE, OR REPAIR, ALL CURBS, SIDEWALKS, PAVEMENT AND OTHER ITEMS DAMAGED BY CONSTRUCTION ACTIVITIES TO AT LEAST THEIR ORIGINAL CONDITION, TO THE SATISFACTION OF THE OWNER AND ENGINEER.
10. WHERE EXISTING PAVEMENT IS REMOVED AND REPLACED, MATCH EXISTING GRADES TO THE EXTENT POSSIBLE. COORDINATE FINE GRADING WITH THE ENGINEER.
11. ALL NON-ROADWAY AREAS THAT ARE EXCAVATED, FILLED, OR OTHERWISE DISTURBED BY THE CONTRACTOR SHALL BE RETURNED TO THEIR EXISTING CONDITION OR BETTER.

CIVIL SITE LAYOUT

- 1. THE CONTRACTOR SHALL BE RESPONSIBLE FOR MAINTAINING THIS PROVIDED LAYOUT INFORMATION THROUGHOUT THE COURSE OF CONSTRUCTION. REPORT ANY LAYOUT DISCREPANCIES IMMEDIATELY TO THE ENGINEER.
2. THE CONTRACTOR SHALL BE RESPONSIBLE FOR RE-ESTABLISHING AND RESETTling ALL EXISTING PROPERTY MONUMENTATION DISTURBED BY CONSTRUCTION. THIS WORK SHALL BE DONE BY A LAND SURVEYOR REGISTERED IN THE STATE OF CONNECTICUT, AT NO ADDITIONAL COST TO THE OWNER.
3. WRITTEN DIMENSIONS SHALL PREVAIL. DO NOT SCALE DISTANCES FROM THE DRAWINGS. REPORT ANY DISCREPANCIES IMMEDIATELY TO THE ENGINEER.
4. EXISTING CONDITIONS SITE PLAN DEVELOPED FROM SURVEY DRAWING PREPARED BY CHW, DATED MARCH 17, 2022.
4.1. NORTH ORIENTATION REFER TO CONNECTICUT STATE PLANE COORDINATE SYSTEM NAD 83.
4.2. ELEVATIONS ARE BASED ON NAVD 88 AND OBTAINED UTILIZING RTK GPS OBSERVATIONS MADE ON 10-21-2021.
4.3. PARCEL OWNER OF RECORD: TOWN OF MONTVILLE, 310 NORWICH- NEW LONDON TURNPIKE, UNCASVILLE, CONNECTICUT
4.4. PARCEL ID: MAP 99, BLOCK 09, TOWN OF ASSESSOR'S MAPPING
4.5. AREA OF PARCEL IS 10,771 SQ.FT., 0.25 ACRES.
4.6. PARCEL IS NOT IN A FLOOD HAZARD ZONE AS DEPICTED ON THE FLOOD INSURANCE RATE MAP, NEW LONDON COUNTY, CONNECTICUT, ALL JURISDICTIONS, PANEL 351 OF 554, MAP NUMBER 09011C03516, MAP REVISED JULY 18, 2011.
4.7. ACCESS EASEMENT IN FAVOR TO THE TOWN OF MONTVILLE OVER PROPERTY OF WICH INC. PER DEED VOL.324 PG. 10
4.8. ACCESS EASEMENT IN FAVOR TO THE TOWN OF MONTVILLE OVER LAND OF ROBERT W. AND DEBORAH KINGSBOROUGH. DEPICTED HEREON BASED ON "TOWN OF MONTVILLE, COOK ROAD WATER MAIN EXTENSION, EASEMENT DESCRIPTION," SCALE: 1"=20', PREPARED BY: CLA ENGINEERS, INC AND DATED: MAY 1999.
4.9. NOT ALL IMPROVEMENTS ARE SHOWN.
4.10. NO WETLANDS FOUND ON SITE PER SOIL SCIENTIST.

CIVIL SITE PIPING

- 1. REFER TO SPECIFICATION SECTION 02200 FOR PIPE AND STRUCTURE BEDDING AND BACKFILL REQUIREMENTS.
2. COMPACTION TESTS WILL BE PERFORMED IN ACCORDANCE WITH SPECIFICATION SECTION 02200. ANY SETTLEMENT OCCURRING WITHIN ONE-YEAR OF FINAL COMPLETION OF THE WORK SHALL BE CORRECTED BY THE CONTRACTOR AT NO ADDITIONAL COST.
3. WHERE NEW PIPING IS TO BE CONNECTED TO EXISTING PIPING, THE CONTRACTOR SHALL FURNISH AND INSTALL ALL ADAPTERS, FITTINGS, AND ADDITIONAL PIPE AS REQUIRED TO COMPLETE THE CONNECTION. CONTRACTOR SHALL VERIFY LOCATION, ELEVATION, ORIENTATION AND MATERIAL OF CONSTRUCTION. TEST PITS SHALL BE USED AS REQUIRED.
4. ALL EXISTING UTILITIES ENCOUNTERED DURING CONSTRUCTION ARE TO REMAIN IN SERVICE UNLESS OTHERWISE NOTED ON THE CIVIL EXISTING CONDITIONS AND DEMOLITION PLAN. ANY EXISTING UTILITIES DAMAGED DURING CONSTRUCTION SHALL BE REPAIRED BY THE CONTRACTOR AT NO ADDITIONAL COST TO THE OWNER.
5. CONTRACTOR SHALL BE RESPONSIBLE FOR REMOVAL AND DISPOSAL OF ALL DEMOLITION MATERIALS IN ACCORDANCE WITH SPECIFICATION SECTION 02050.

WATER MAIN GENERAL NOTES

- 1. WHERE NEW PIPING IS TO BE CONNECTED TO EXISTING PIPING, THE CONTRACTOR SHALL FURNISH AND INSTALL ALL ADAPTERS, FITTINGS, AND ADDITIONAL PIPE AS REQUIRED TO COMPLETE THE CONNECTION. CONTRACTOR SHALL VERIFY LOCATION, ELEVATION, ORIENTATION AND MATERIAL OF CONSTRUCTION. TEST PITS SHALL BE USED AS REQUIRED.
2. ANY UNDERGROUND STRUCTURES, CABLES, AND PIPELINES LOCATED ADJACENT TO THE TRENCH EXCAVATIONS SHALL BE PROTECTED AND FIRMLY SUPPORTED BY THE CONTRACTOR UNTIL THE TRENCH IS BACKFILLED. DAMAGE TO ANY SUCH STRUCTURES, CABLES, AND PIPELINES SHALL BE REPAIRED AT THE CONTRACTOR'S EXPENSE AND TO THE SATISFACTION OF THE OWNERS OF THE STRUCTURES, CABLES, AND PIPELINES.

- 3. THE CONTRACTOR SHALL BE RESPONSIBLE FOR THE LAYOUT OF THE NEW WATER MAIN. LAYOUT SHALL BE REVIEWED AND ACCEPTED BY THE OWNER AND ENGINEER. THE NEW WATER MAIN MUST BE LOCATED WITHIN THE RIGHTS-OF-WAY SHOWN ON THE DRAWINGS.
4. MINIMUM DEPTH OF COVER SHALL BE 4'-0". AND MAXIMUM DEPTH OF COVER SHALL BE 7'-0". UNLESS SHOWN OTHERWISE ON THE DRAWINGS. THE NEW MAIN SHALL GENERALLY FOLLOW THE GROUND CONTOUR, HOWEVER, ABRUPT CHANGES IN GRADE SHALL BE AVOIDED. AT LOCAL HIGH POINTS OR WHERE AIR RELEASE VALVES ARE SHOWN, THE CONTRACTOR SHALL SLOPE NEW MAIN AS NEEDED TO MAINTAIN. INSULATE OVER WATER MAIN WHEN COVER IS LESS THAN 4.0 FT. CONTRACTOR TO PROVIDE INSULATION.
5. ALL BENDS, TEES, REDUCERS, HYDRANTS AND PLUGS SHALL BE RESTRAINED BY USING CONCRETE THRUST BLOCKS AND GRIP-RINGS OR OTHER METHOD AS SHOWN ON THE DRAWINGS. ANCHOR TEES SHALL BE USED FOR ALL HYDRANT BRANCHES.
6. TEST PRESSURES FOR THE COMBINATION PRESSURE AND LEAKAGE TESTS SHALL BE 150 PSI. TEST DURATION SHALL BE TWO HOURS.
7. CONNECTIONS TO EXISTING WATER MAIN SHALL BE COORDINATED WITH THE OWNER.
8. ALL WATER MAINS THAT ARE DISCONNECTED FROM THE WATER SYSTEM AND ARE TO BE LEFT IN PLACE SHALL BE CAPPED WITH A M.J. CAP OR PLUG.
9. ALL EXISTING UTILITIES ENCOUNTERED DURING CONSTRUCTION ARE TO REMAIN IN SERVICE UNLESS OTHERWISE NOTED. AT NO ADDITIONAL COST TO THE OWNER THE CONTRACTOR SHALL REPAIR OR COORDINATE WITH THE RESPECTIVE UTILITY ON DAMAGE TO EXISTING UTILITIES.
10. CONTINUOUS WATER SERVICE MUST BE MAINTAINED DURING CONSTRUCTION. THE CONTRACTOR SHALL PROVIDE TEMPORARY PIPING AND SERVICES SUITABLE FOR AN OPERATING PRESSURE OF 100PSI. ACCESS TO ROAD AND DRIVEWAYS SHALL ALSO BE MAINTAINED.
11. EXISTING VALVES AND FITTINGS SALVAGED FOR REUSE SHALL BE STORED AT AN OWNER APPROVED LOCATION AND REMAIN PROPERTY OF THE OWNER.
12. ALL VALVES SHALL OPEN LEFT.
13. ALL EXISTING SYSTEM VALVES ARE TO BE OPERATED SOLELY BY THE OWNER. COORDINATION OF WORK WHICH MAY AFFECT OR DISRUPT THE OPERATION OF EXISTING UTILITIES MUST BE MADE 7 DAYS IN ADVANCE. COORDINATION OF REMOVING THE EXISTING TANK FROM SERVICE MUST OCCUR 2 WEEKS IN ADVANCE.
14. NOT ALL PROPOSED FITTINGS HAVE BEEN SHOWN ON THE DRAWINGS. THE CONTRACTOR SHALL INSTALL ALL FITTINGS, BENDS AND APPURTENANCES TO ACCOMMODATE THE PIPING LAYOUTS SHOWN IN ACCORDANCE WITH ALL PERTINENT CODES AND STANDARDS, PER MANUFACTURER'S RECOMMENDATIONS, AND AS DIRECTED BY THE ENGINEER.
15. NEW HYDRANT SHALL BE FIELD LOCATED AND APPROVED AND INSPECTED BY THE OWNER.
16. NO WATER MAIN OR SERVICE MAIN SHALL BE CONNECTED TO THE EXISTING SYSTEM UNTIL THE MAIN HAS BEEN DISINFECTED, TESTED AND ACCEPTED. THE CONTRACTOR SHALL COORDINATE WITH THE OWNER THE FILLING, FLUSHING AND TESTING OF THE WATER MAIN. THE CONTRACTOR SHALL NOT OPERATE ANY OF THE LIVE WATER INFRASTRUCTURE WITHIN THE PROJECT AREA.
17. CONTRACTOR SHALL SUBMIT, TO THE OWNER FOR APPROVAL, HIS/HER INTENDED, DETAILED METHODS FOR TESTING AND DISINFECTING THE NEW WATER MAINS. INCLUDE LIST OF EQUIPMENT, SEQUENCE, SKETCHES, ETC. AS REQUIRED.
18. IN THE EVENT THE WATER MAIN FAILS TO MEET THE REQUIRED PHYSICAL, CHEMICAL AND BIOLOGICAL PARAMETERS, THE CONTRACTOR SHALL BE RESPONSIBLE FOR INJECTING THE WATER MAIN WITH THE PROPER QUANTITY OF LIQUID HYPOCHLORITE SOLUTION, AT NO ADDITIONAL COST TO THE OWNER. THE CONTRACTOR SHALL ALSO BE RESPONSIBLE FOR ALL COSTS ASSOCIATED WITH ANY ADDITIONAL TESTING REQUIRED IF INITIAL TESTS FAIL.

STRUCTURAL DESIGN CRITERIA

REFERENCE SPECIFICATION 13004
ALLOWABLE SUBGRADE BEARING PRESSURE = 20 TONS/5F
MINIMUM FROST DEPTH = 4 FEET
LIVE LOADS:
REF: 2018 CONNECTICUT STATE BUILDING CODE
2015 INTERNATIONAL BUILDING CODE
ASCE 7-10 MINIMUM DESIGN LOADS FOR BUILDINGS AND OTHER STRUCTURES
OCCUPANCY RISK CATEGORY IV
WIND LOADS:
BASIC WIND SPEED (V): Vult = 142 MPH
Vasd = 109 MPH
IMPORTANCE FACTOR (Iw) = 1.0
EXPOSURE CATEGORY C
SNOW LOADS:
GROUND SNOW LOAD (Pg) = 30 PSF
IMPORTANCE FACTOR (Is) = 1.2
EXPOSURE FACTOR (Ce) = 1.1
THERMAL FACTOR (Ct) = 1.2
EXPOSURE CATEGORY C
SLOPE FACTOR (Cs) = 1.1
SEISMIC LOADS:
EQUIVALENT LATERAL FORCE ANALYSIS
IMPORTANCE FACTOR (Ie) = 1.5
SITE CLASSIFICATION C
0.2s SPECTRAL RESPONSE ACCELERATION (Ss) = 0.059
1.0s SPECTRAL RESPONSE ACCELERATION (S1) = 0.165

CIVIL ABBREVIATIONS

Table with 2 columns: Abbreviation and Description. Includes symbols for diameters, materials, and various pipe types.

LEGEND

Table with 3 columns: EXISTING, PROPERTY/ROW LINE, and PROPOSED. Lists various symbols and line styles for different features like easements, curbing, manholes, and wetlands.

Project information block including drawing title 'TOWN OF MONTVILLE, CONNECTICUT COOK HILL TANK REPLACEMENT PROJECT MONTVILLE WATER SUPPLY', project number '2018IBT', designer 'B. PAIRTH', and a large 'WRIGHT-PIERCE' logo with contact information.

EROSION AND SEDIMENTATION CONTROL NOTES:

THIS PLAN HAS BEEN DEVELOPED AS A STRATEGY TO CONTROL SOIL EROSION AND SEDIMENTATION DURING AND AFTER CONSTRUCTION. THIS PLAN IS BASED ON THE "2002 CONNECTICUT GUIDELINES FOR SOIL EROSION AND SEDIMENT CONTROL" BY THE CONNECTICUT COUNCIL ON SOIL AND WATER CONSERVATION IN COOPERATION WITH THE CONNECTICUT DEPARTMENT OF ENERGY AND ENVIRONMENTAL PROTECTION.

THE PROPOSED LOCATIONS OF SILTATION AND EROSION CONTROL MEASURES REQUIRED ARE SHOWN ON THE EROSION CONTROL NOTES AND DETAILS PLAN, REFER TO DRAWING C-4. PROVIDE SILT FENCE, STONE CHECK DAMS, AND OTHER EROSION CONTROL MEASURES AS REQUIRED TO ADEQUATELY PREVENT SEDIMENT TRANSPORT AS NOTED IN THE BMP.

- ALL SEDIMENT AND EROSION CONTROL MEASURES SHALL BE DONE IN ACCORDANCE WITH THE "2002 CONNECTICUT GUIDELINES FOR SOIL EROSION AND SEDIMENT CONTROL" BY THE CONNECTICUT COUNCIL ON SOIL AND WATER CONSERVATION IN COOPERATION WITH THE CONNECTICUT DEPARTMENT OF ENVIRONMENTAL PROTECTION.
- THOSE AREAS UNDERGOING ACTUAL CONSTRUCTION WILL BE MAINTAINED IN AN UNTREATED OR NON-VEGETATED CONDITION FOR THE MINIMUM TIME REQUIRED. IN GENERAL, AREAS TO BE VEGETATED SHALL BE PERMANENTLY STABILIZED WITHIN 15 DAYS OF FINAL GRADING AND TEMPORARILY STABILIZED WITHIN 30 DAYS OF INITIAL DISTURBANCE OF THE SOIL.
- SEDIMENT BARRIERS (SILT FENCE, STONE CHECK DAMS, ETC.) SHOULD BE INSTALLED PRIOR TO ANY SOIL DISTURBANCE OF UPGRADIENT DRAINAGE AREAS.
- INSTALL SILT FENCE AT TOE OF SLOPES TO FILTER SILT FROM RUNOFF. SEE SILT FENCE DETAIL FOR PROPER INSTALLATION. SILT FENCE WILL REMAIN IN PLACE PER NOTE 5.
- ALL EROSION CONTROL STRUCTURES WILL BE INSPECTED, REPLACED, AND/OR REPAIRED EVERY 7 DAYS AND IMMEDIATELY FOLLOWING ANY SIGNIFICANT RAINFALL OR SNOW MELT OR WHEN NO LONGER SERVICEABLE DUE TO SEDIMENT ACCUMULATION OR DECOMPOSE. SEDIMENT DEPOSITS MUST BE REMOVED WHEN DEPOSITS REACH APPROXIMATELY ONE HALF THE HEIGHT OF THE BARRIER. SEDIMENT CONTROL DEVICES SHALL REMAIN IN PLACE AND BE MAINTAINED BY THE CONTRACTOR UNTIL AREAS UPSLOPE ARE PERMANENTLY STABILIZED.
- NO SLOPES, EITHER PERMANENT OR TEMPORARY, SHALL BE STEEPER THAN TWO HORIZONTAL TO ONE VERTICAL (2 TO 1) UNLESS STABILIZED WITH PERMANENT EROSION CONTROL MEASURES.
- IF FINAL SEEDING OF THE DISTURBED AREAS IS NOT TO BE COMPLETED 30 DAYS PRIOR TO THE ANTICIPATED DATE OF THE FIRST KILLING FROST, USE TEMPORARY MULCHING (DORMANT SEEDING MAY BE ATTEMPTED AS WELL) TO PROTECT THE SITE AND DELAY PERMANENT SEEDING, UNTIL UPGRADIENT AREAS ARE STABILIZED.
- WHEN FEASIBLE, TEMPORARY SEEDING OF DISTURBED AREAS THAT HAVE NOT BEEN FINISH-GRADED SHALL BE COMPLETED 30 DAYS PRIOR TO THE FIRST KILLING FROST.
- DURING THE CONSTRUCTION PHASE, INTERCEPTED SEDIMENT WILL BE RETURNED TO THE SITE AND REGRADED ONTO OPEN AREAS. POST SEEDING SEDIMENT, IF ANY, WILL BE DISPOSED OF IN AN ACCEPTABLE MANNER.
- REVEGETATION MEASURES WILL COMMENCE UPON COMPLETION OF CONSTRUCTION EXCEPT AS NOTED ABOVE. ALL DISTURBED AREAS NOT OTHERWISE STABILIZED WILL BE GRADED, SMOOTHED, AND REVEGETATED AS FOLLOWS:
 - A. A MINIMUM OF FOUR INCHES (4") OF LOAM WILL BE SPREAD OVER DISTURBED AREAS AND SMOOTHED TO A UNIFORM SURFACE.
 - B. APPLY LIMESTONE AND FERTILIZER ACCORDING TO SOIL TEST. IF SOIL TESTING IS NOT DEEMED FEASIBLE ON SMALL OR VARIABLE SITES, OR WHERE TIMING IS CRITICAL, FERTILIZER MAY BE APPLIED AT THE RATE OF 300 POUNDS PER ACRE OR 7.5 POUNDS PER 1,000 SQUARE FEET USING 10-10-10 (N-P205-K20) OR EQUIVALENT. APPLY GROUND LIMESTONE (EQUIVALENT TO 50% CALCIUM PLUS MAGNESIUM OXIDE) AT A RATE OF 4 TONS PER ACRE (180 POUNDS PER 1,000 SQUARE FEET) FOR CLAY, CLAY LOAM, AND HIGH ORGANIC SOIL. AT A RATE OF 3 TONS PER ACRE (135 POUNDS PER 1,000 SQUARE FEET) FOR SANDY LOAM, LOAM AND SILT LOAM. AT A RATE OF 2 TONS PER ACRE (90 POUNDS PER 1,000 SQUARE FEET) FOR LOAMY SAND, AND SAND.
 - C. FOLLOWING SEED BED PREPARATION, DITCHES AND BACK SLOPES WILL BE SEEDED WITH A MIXTURE OF 47% CREEPING RED FESCUE, 5% REDTOP, AND 48% TALL FESCUE. THE LAWN AREAS WILL BE SEEDED WITH A PREMIUM TURF MIXTURE OF 44% KENTUCKY BLUEGRASS, 44% CREEPING RED FESCUE, AND 12% PERENNIAL RYE GRASS. SEEDING RATE IS 3.0 POUNDS PER 1,000 SQUARE FEET. LAWN QUALITY SOD MAY BE SUBSTITUTED FOR SEED.
 - D. HAY MULCH AT THE RATE OF 2 TONS PER ACRE OR 90-95 POUNDS PER 1,000 SQUARE FEET OR A HYDRO-APPLICATION OF CELLULOSE FIBER SHALL BE APPLIED FOLLOWING SEEDING. A SUITABLE BINDER WILL BE USED ON HAY MULCH FOR WIND CONTROL.
- ALL TEMPORARY EROSION CONTROL MEASURES SHALL BE REMOVED ONCE THE WORK AREA IS STABILIZED.
- WETLANDS (EXCEPTING THOSE WHICH ARE TO BE FILLED IN ACCORDANCE WITH STATE AND FEDERAL REGULATIONS) WILL BE PROTECTED WITH SILT FENCE INSTALLED AT THE EDGE OF THE WETLAND OR THE BOUNDARY OF WETLAND DISTURBANCE.
- IN GENERAL, AREAS WITHIN 100 FEET OF DELINEATED WETLANDS OR STREAMS SHALL HAVE A MAXIMUM PERIOD OF EXPOSURE OF NOT MORE THAN 15 DAYS.
- FOLLOW APPROPRIATE EROSION CONTROL MEASURES PRIOR TO EACH STORM IN ALL AREAS WITHIN 100 FEET OF DELINEATED WETLANDS OR STORMS.

EROSION CONTROL DURING WINTER CONSTRUCTION:

- WINTER CONSTRUCTION PERIOD DEFINED: NOVEMBER 1 THROUGH APRIL 15.
- WINTER EXCAVATION AND EARTHWORK SHALL BE DONE SUCH THAT NO MORE THAN 1 ACRE OF THE SITE IS WITHOUT STABILIZATION AT ANY ONE TIME.
- EXPOSED AREA SHOULD BE LIMITED TO THAT WHICH CAN BE MULCHED IN ONE DAY PRIOR TO ANY PRECIPITATION EVENT.
- AN AREA SHALL BE CONSIDERED TO HAVE BEEN STABILIZED WHEN EXPOSED SURFACES HAVE BEEN EITHER MULCHED WITH STRAW OR HAY AT A RATE OF 100 POUNDS PER 1,000 SQUARE FEET (WITH OR WITHOUT SEEDING) OR DORMANT SEED, MULCHED, AND ADEQUATELY ANCHORED BY AN APPROVED ANCHORING TECHNIQUE. IN ALL CASES, MULCH SHALL BE APPLIED SUCH THAT SOIL SURFACE IS NOT VISIBLE THROUGH THE MULCH.
- BETWEEN THE DATES OF OCTOBER 15 AND APRIL 1, LOAM OR SEED WILL NOT BE REQUIRED. DURING PERIODS OF ABOVE-FREEZING TEMPERATURES, THE SLOPES SHALL BE FINE GRADED AND EITHER PROTECTED WITH MULCH OR TEMPORARILY SEEDED AND MULCHED UNTIL SUCH TIME AS THE FINAL TREATMENT CAN BE APPLIED. IF THE DATE IS AFTER NOVEMBER 1 AND IF THE EXPOSED AREA HAS BEEN LOAMED, FINAL GRADED, AND IS SMOOTH, THEN THE AREA MAY BE DORMANT SEED AT A RATE 200%-300% HIGHER THAN SPECIFIED FOR PERMANENT SEED AND THEN MULCHED. IF CONSTRUCTION CONTINUES DURING FREEZING WEATHER, ALL EXPOSED AREAS SHALL BE GRADED BEFORE FREEZING AND THE SURFACE TEMPORARILY PROTECTED FROM EROSION BY THE APPLICATION OF MULCH. SLOPES SHALL NOT BE LEFT EXPOSED OVER THE WINTER OR ANY OTHER EXTENDED TIME OF WORK SUSPENSION UNLESS TREATED IN THE ABOVE MANNER. UNTIL SUCH TIME AS WEATHER CONDITIONS PERMIT, ALL DITCHES TO BE FINISHED WITH THE PERMANENT SURFACE TREATMENT, EROSION SHALL BE CONTROLLED BY THE INSTALLATION OF BALES OF HAY OR STONE CHECK DAMS IN ACCORDANCE WITH THE STANDARD DETAILS.
- A) BETWEEN THE DATES OF NOVEMBER 1 AND APRIL 15, ALL MULCH SHALL BE EITHER WOOD CELLULOSE FIBER OR BE ANCHORED WITH MULCH NETTING OR CHEMICAL TACK.
 - B) MULCH NETTING SHALL BE USED TO ANCHOR MULCH IN ALL DRAINAGE WAYS WITH A SLOPE GREATER THAN 3%, FOR SLOPES EXPOSED TO DIRECT WINDS AND FOR ALL OTHER SLOPES GREATER THAN 8%.
 - C) MULCH NETTING SHALL BE USED TO ANCHOR MULCH IN ALL AREAS WITH SLOPES GREATER THAN 15%. AFTER OCTOBER 1, THE SAME APPLIES FOR ALL SLOPES GREATER THAN 8%.
- AFTER NOVEMBER 1, THE CONTRACTOR SHALL APPLY DORMANT SEEDING OR MULCH AND ANCHORING ON ALL BARE EARTH AT THE END OF EACH WORKING DAY.
- DURING WINTER CONSTRUCTION PERIODS, ALL SNOW SHALL BE REMOVED FROM AREAS OF SEEDING AND MULCHING PRIOR TO PLACEMENT.

MULCH ANCHORING:

ANCHOR MULCH WITH: MULCH NETTING (AS PER MANUFACTURER); ASPHALT EMULSION (0.05 GALLONS PER SQUARE YARD); CHEMICAL TACK (AS PER MANUFACTURER'S SPECIFICATIONS); OR BE WOOD CELLULOSE FIBER (2,000 POUNDS PER ACRE). WETTING FOR SMALL AREAS AND ROAD DITCHES MAY BE PERMITTED.

MULCH AND MULCH ANCHORING

LOCATION	MULCH	RATE (1000 S.F.)
PROTECTED AREA	STRAW OR HAY *	100 POUNDS
WINDY AREAS	STRAW OR HAY (ANCHORED) *	100 POUNDS
MODERATE TO HIGH VELOCITY AREAS OR STEEP SLOPES (GREATER THAN 3:1)	JUTE MESH, EXCELSIOR MAT, OR EQUIV.	AS REQUIRED

* A HYDRO-APPLICATION OF CELLULOSE FIBER MAY BE APPLIED FOLLOWING SEEDING. A SUITABLE BINDER SHALL BE USED ON HAY MULCH FOR WIND CONTROL.

ADDITIONAL TEMPORARY SEED MIXTURE (OR PERIODS LESS THAN 12 MONTHS)

DATES	SEED	RATE
3/1 - 6/15	OATS	86 LBS/ACRE
8/15 - 9/15		
3/1 - 6/15	ANNUAL RYE GRASS	40 LBS/ACRE
8/1 - 10/15		
4/15 - 7/1	WINTER RYE	120 LBS/ACRE
(8/15 - 10/15)		
5/15 - 7/15	MILLET	20 LBS/ACRE

* SEED RATE ONLY

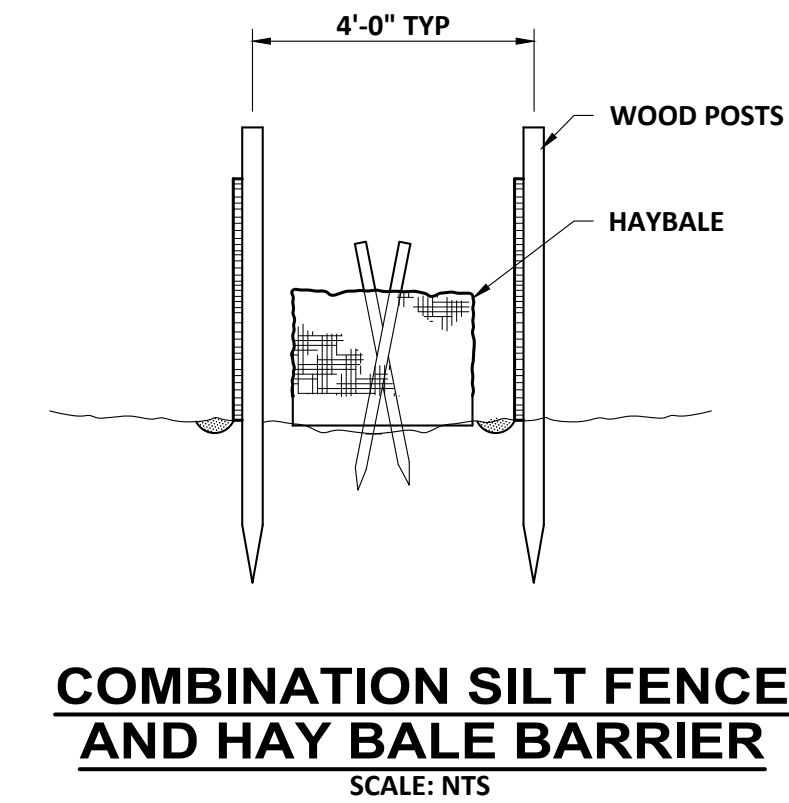
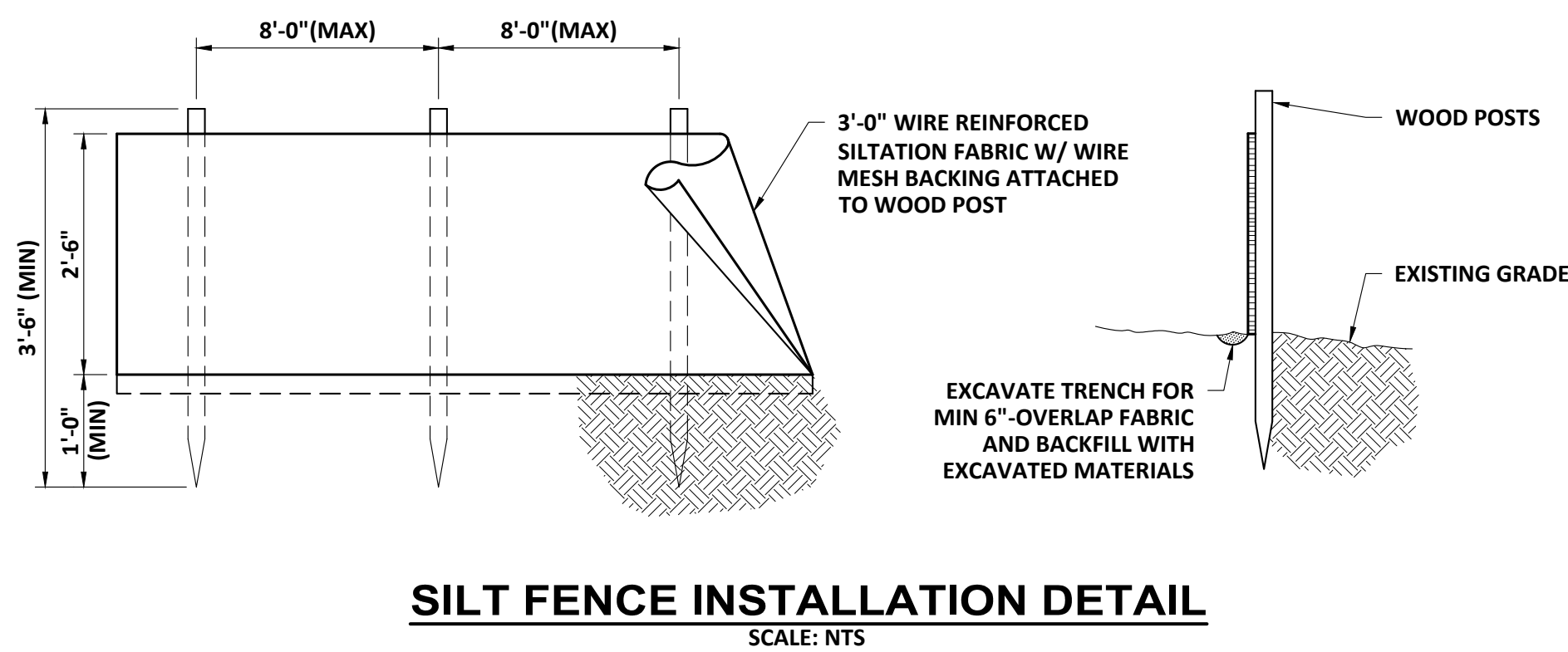

SILT FENCE INSTALLATION DETAIL
SCALE: NTS

COMBINATION SILT FENCE AND HAY BALE BARRIER
SCALE: NTS

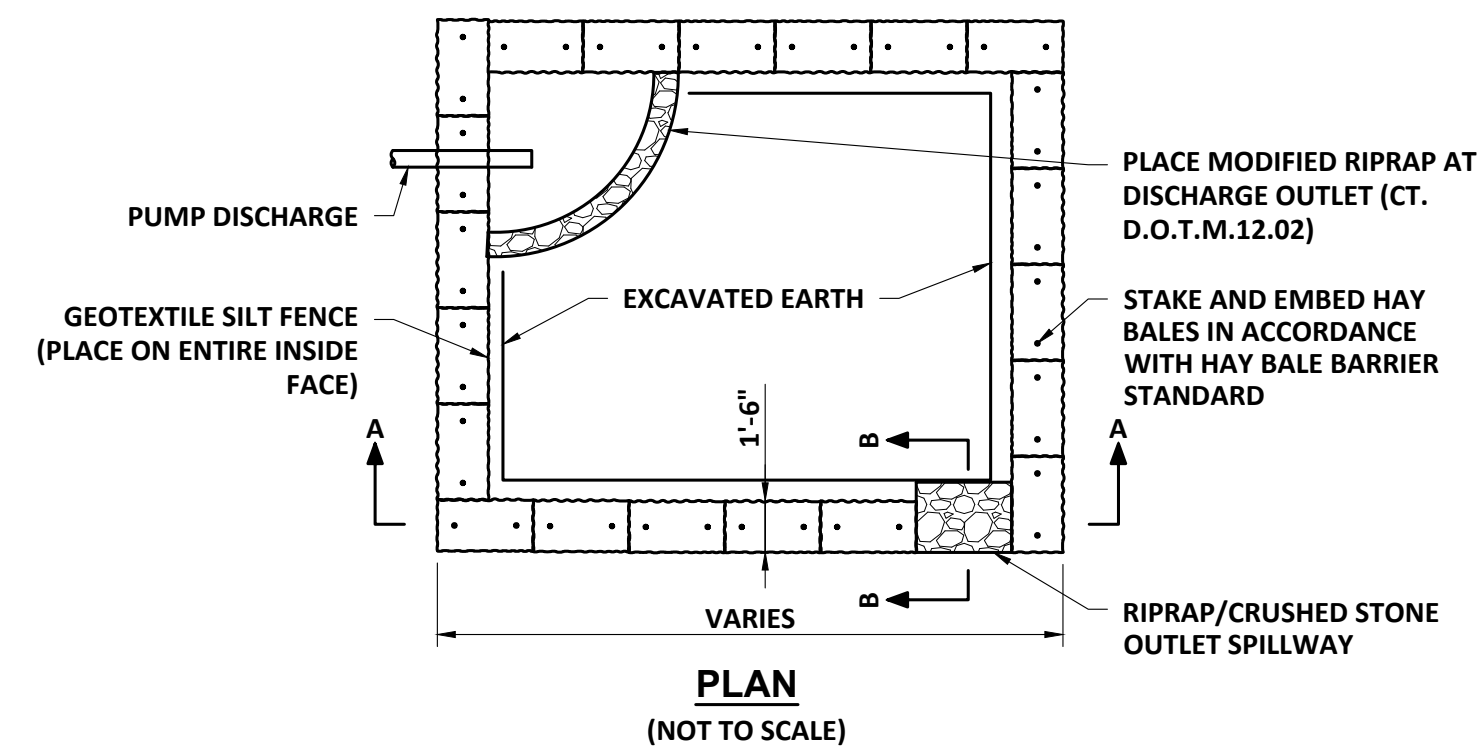

PLAN
(NOT TO SCALE)

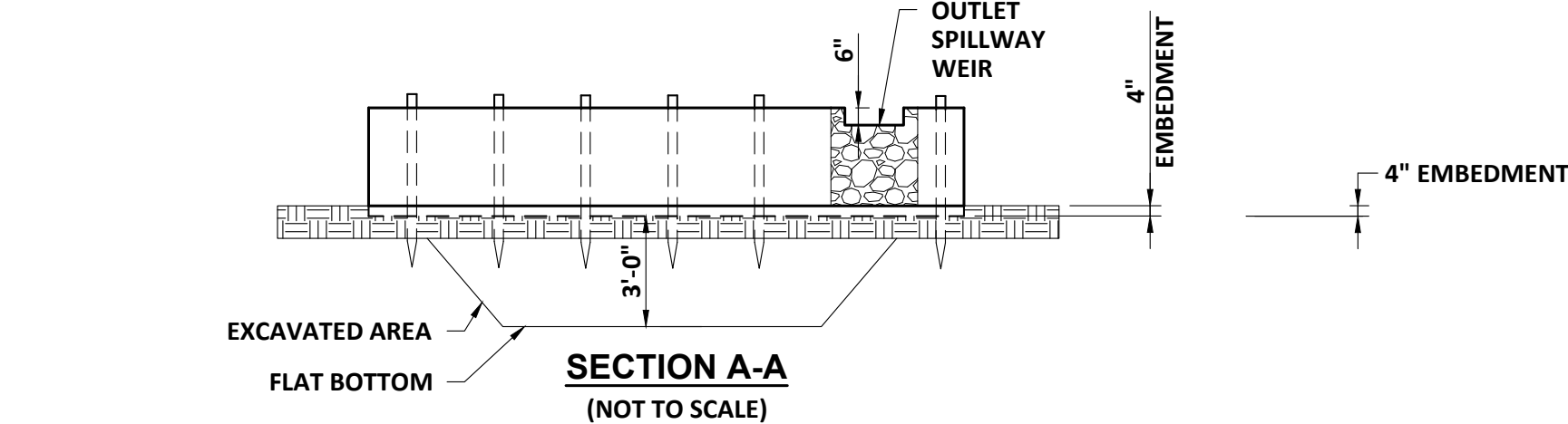

SECTION A-A
(NOT TO SCALE)

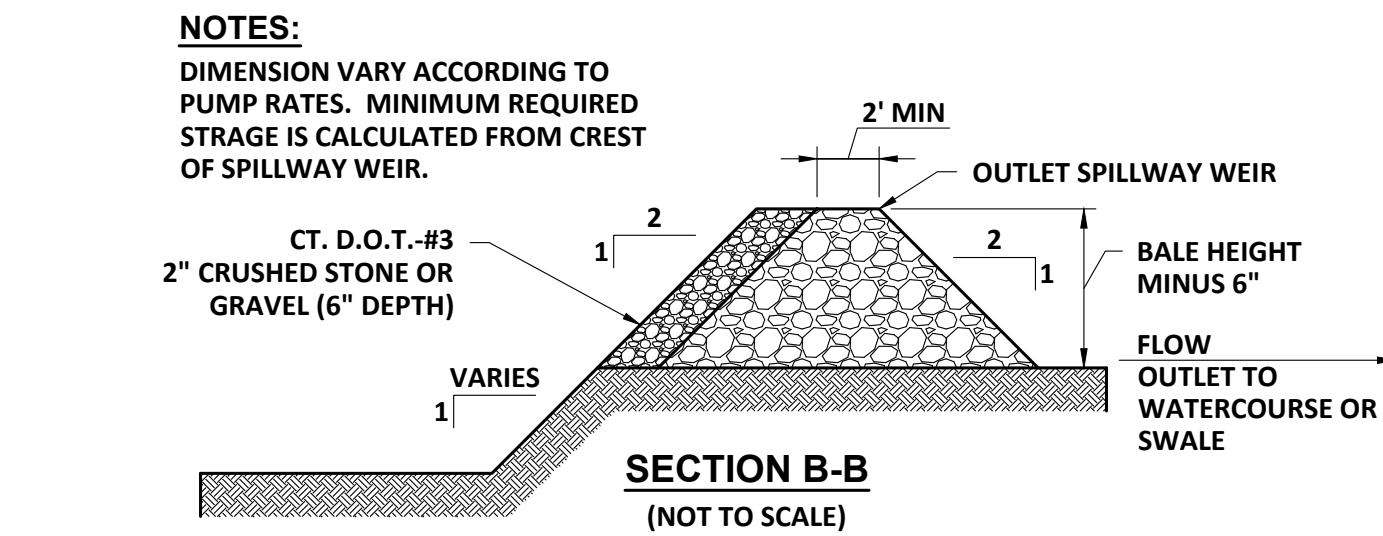

SECTION B-B
(NOT TO SCALE)

TYPE II SEDIMENTATION BASIN DETAIL
SCALE: NTS

NOTES:
DIMENSION VARY ACCORDING TO PUMP RATES. MINIMUM REQUIRED STRAGE IS CALCULATED FROM CREST OF SPILLWAY WEIR.

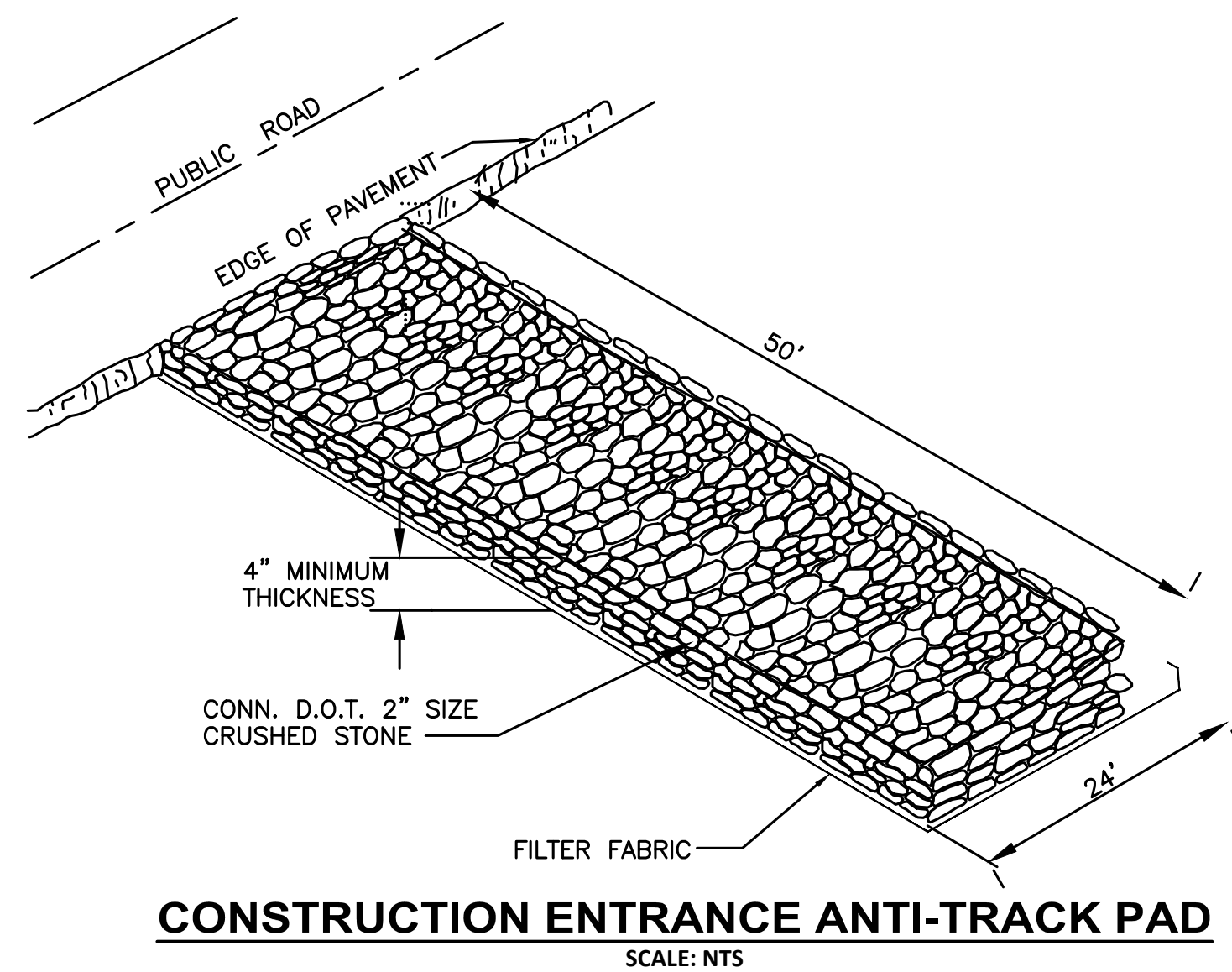

CONSTRUCTION ENTRANCE ANTI-TRACK PAD
SCALE: NTS

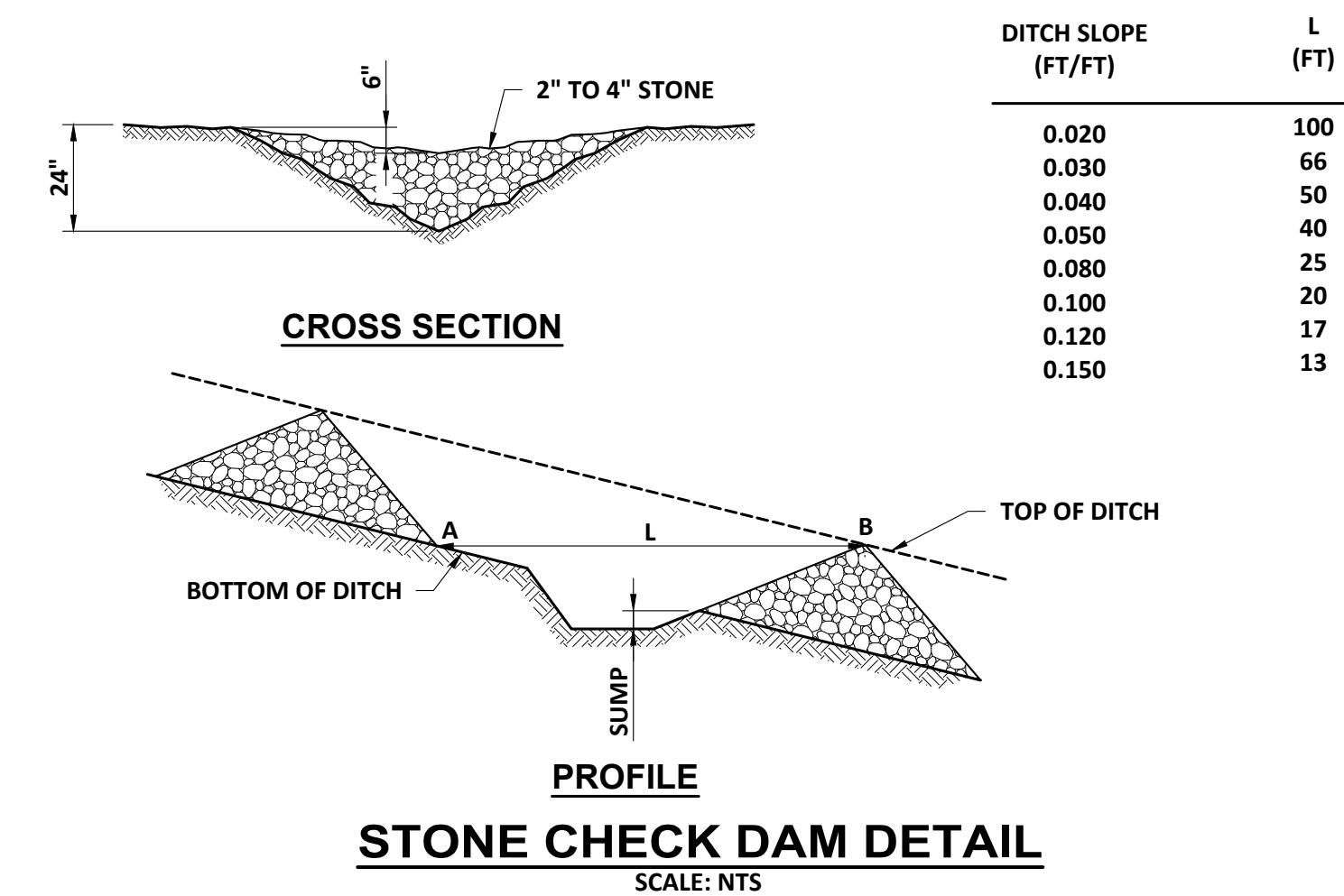

STONE CHECK DAM DETAIL
SCALE: NTS

NO	REVISIONS	APPD	DATE

PROJECT NO: 20410B	DESIGNED: B. PARTIT	CAD COORD: S. COCHRAN	CHECKED: S. COCHRAN	DATE: 08-22	APPROVED: S. COCHRAN	DATE: 08-22	SUBMISSION: PERMITTING REVIEW
--------------------	---------------------	-----------------------	---------------------	-------------	----------------------	-------------	-------------------------------

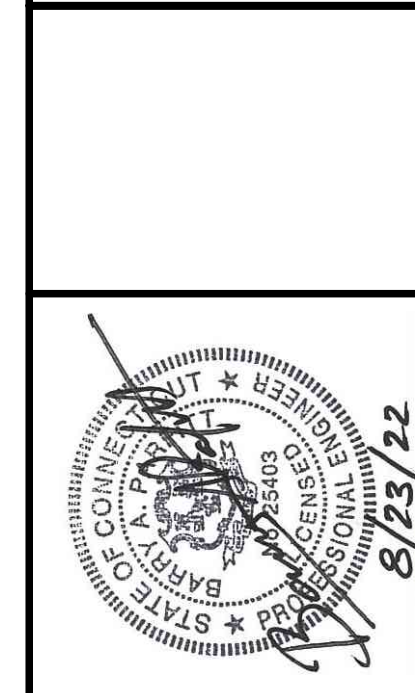

WRIGHT-PIERCE
860.343.8297 | www.wright-pierce.com
169 MAIN STREET, 700 PLAZA MIDDLESEX, MIDDLETOWN, CT 06457

TOWN OF MONTVILLE, CONNECTICUT
COOK HILL TANK
REPLACEMENT PROJECT
MONTVILLE WATER SUPPLY

EROSION CONTROL NOTES AND DETAILS

DRAWING
C-4



- LOCATION MAP
SCALE: 1"=1000'
- 1) NORTH ORIENTATION REFER TO CONNECTICUT STATE PLANE COORDINATE SYSTEM NAD 83.
 - 2) ELEVATIONS ARE BASED ON NAVD 88 AND OBTAINED UTILIZING RTK GPS OBSERVATIONS MADE ON 10-21-2021.
 - 3) PARCEL OWNER OF RECORD: TOWN OF MONTVILLE
50 COOK DR
MONTVILLE, CONNECTICUT
 - 4) PARCEL ID: MAP 99, BLOCK 09, LOT 01, TOWN OF MONTVILLE ASSESSOR'S MAPPING
 - 5) AREA OF PARCEL IS 10,771.25 SQ.FT., 0.25 ACRES.
 - 6) PARCEL IS NOT IN A FLOOD HAZARD ZONE AS DEPICTED ON THE FLOOD INSURANCE RATE MAP, NEW LONDON COUNTY, CONNECTICUT, ALL JURISDICTIONS, PANEL 351 OF 554, MAP NUMBER 0901C0351G, MAP REVISED JULY 18, 2011.
 - 7) ACCESS EASEMENT IN FAVOR TO THE TOWN OF MONTVILLE OVER PROPERTY OF WICH INC. PER DEED VOL.324 PG. 10
 - 8) ACCESS EASEMENT IN FAVOR TO THE TOWN OF MONTVILLE OVER LAND OF ROBERT W. AND DEBORAH KINGSBOROUGH. DEPICTED HEREON BASED ON MAP REFERENCE #2.
 - 9) PARCEL SUBJECT TO 50' RIGHT OF WAY FOR ROADWAY USE.
 - 10) NOT ALL IMPROVEMENTS ARE SHOWN.
 - 11) NO WETLANDS FOUND ON SITE PER SOIL SCIENTIST.

- MAP REFERENCES:
- 1) "TOWN OF MONTVILLE, COOK ROAD DRAINAGE AND WATER MAIN IMPROVEMENTS, PLAN AND PROFILE," SCALE: 1"=40', PREPARED BY: CLA ENGINEERS, INC AND DATED: MAY 1999.
 - 2) "TOWN OF MONTVILLE, COOK ROAD WATER MAIN EXTENSION, EASEMENT DESCRIPTION," SCALE: 1"=20', PREPARED BY: CLA ENGINEERS, INC AND DATED: MAY 1999.
 - 3) "THE VILLAGE AT SHANTOK HILL SUBDIVISION, PROPERTY OF VIZION ENTERPRISES, SCALE: 1"=50', PREPARED BY: DICASARE BENTLEY AND DATED: MAY 23, 2014.
 - 4) "PLAN SHOWING PROPERTY OF RICHARD GLADUE, 44 COOK DRIVE, MONTVILLE CONNECTICUT," SCALE: 1"=20', DATED: APRIL 21, 1994.
 - 5) "MOHEGAN HILL SUBDIVISION OF LAND OF DAVID KINGSBOROUGH, ET AL OFF POLLY'S LANE, UNCASVILLE CONNECTICUT," SCALE: 1"=200', PREPARED BY: KING & MULLEN LAND SURVEYORS AND DATED: JANUARY 12, 1988.
 - 6) "TOWN OF MONTVILLE, PLAN SHOWING TRACT 182 OWNED BY PETER & RITA COLEDA TO BE PURCHASED BY RUDOLPH CARON," SCALE: 1"=40', DATED: AUGUST 1962.

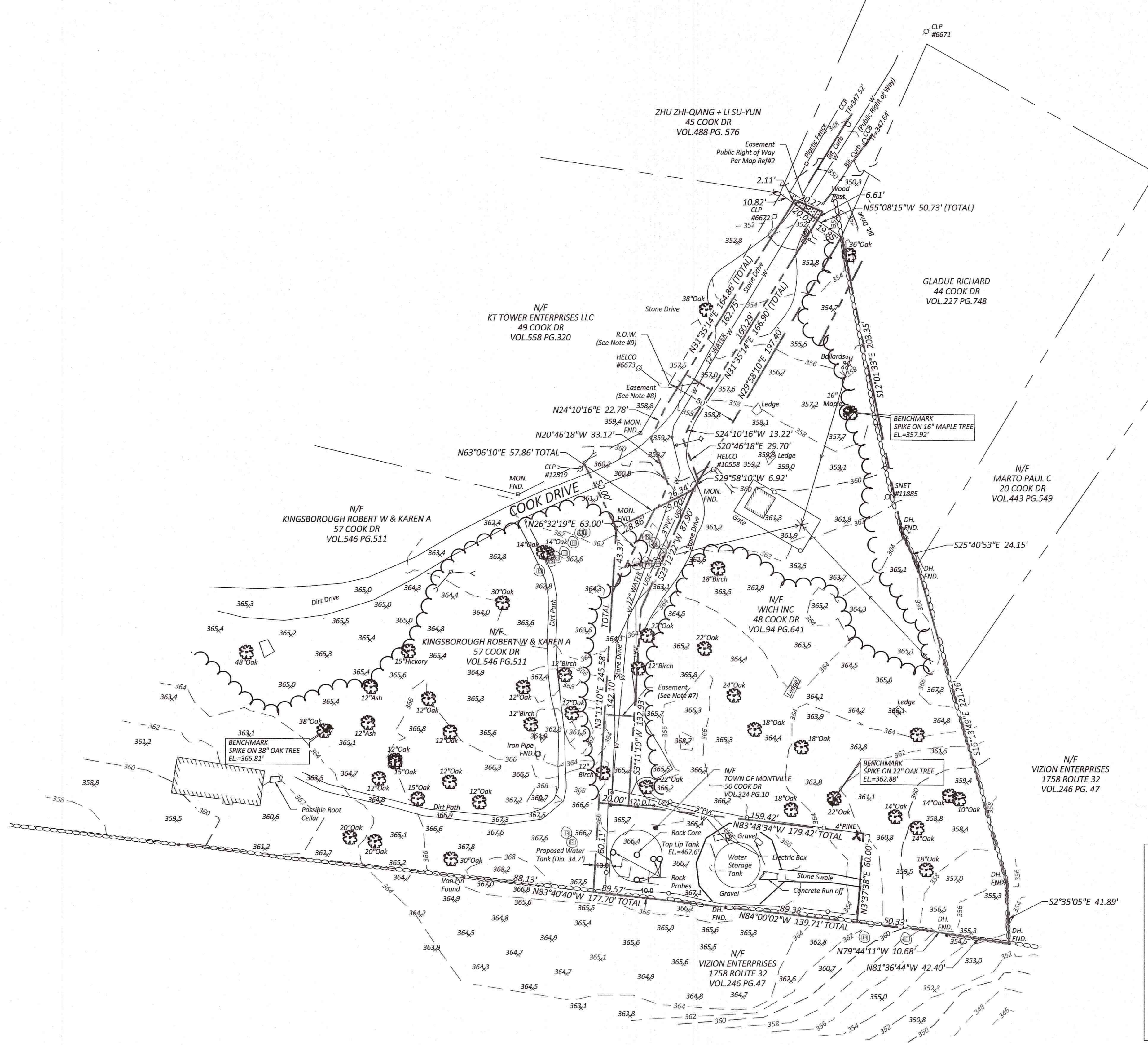
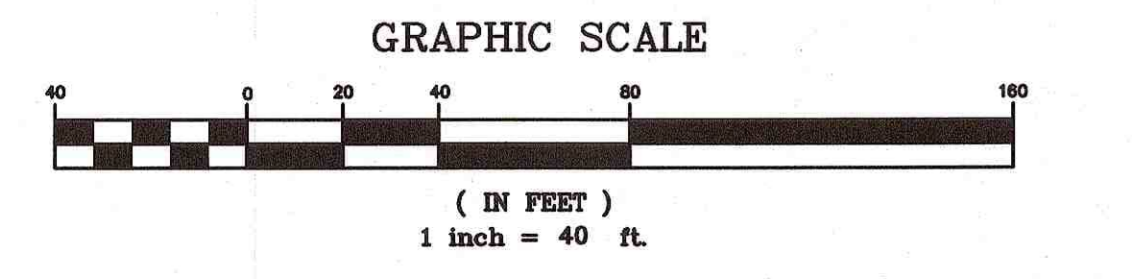

SYMBOLS LEGEND

	Utility Pole		Mailbox
	Utility Pole w/ Guy		Property Line
	Guy Anchor		Easement Line
	Deciduous Tree		Contour Line
	Water Gate		Spot Grade
	Fire Hydrant		Chain Link Fence
	Iron Pin		Stone Wall
	Drill Hole		Treeline
	Boulder		Underground Water Line
			Underground Electric Line

NOTES:
INDICATED UNDERGROUND UTILITIES ARE BASED ON ACTUAL FIELD LOCATIONS AND AVAILABLE NOTES AND MAPPING BY OTHERS. THE LOCATIONS ARE APPROXIMATE AND ALL UTILITIES MAY NOT BE SHOWN. PRIOR TO ANY CONSTRUCTION THE CONTRACTOR SHALL HAVE ALL UTILITIES MARKED ON THE GROUND.

MCA
MARTINEZ COUCH & ASSOCIATES LLC
ENGINEERING • LAND SURVEYING • ENVIRONMENTAL
CONSTRUCTION INSPECTION • GIS • WASTEWATER

1084 Cromwell Avenue, Suite A-2
Rocky Hill, CT 06067
Telephone: (860) 436-4364
Fax: (860) 436-4626
www.martinezcouch.com

MONTVILLE WATER TANK
50 COOK DRIVE
MONTVILLE, CONNECTICUT
PREPARED FOR: WRIGHT-PIERCE

THIS SURVEY AND MAP HAS BEEN PREPARED IN ACCORDANCE WITH SECTIONS 20-300B-1 THRU 20-300B-20 OF THE REGULATIONS OF CONNECTICUT STATE AGENCIES-"MINIMUM STANDARDS FOR SURVEYS AND MAPS IN THE STATE OF CONNECTICUT" AS ENDORSED BY THE CONNECTICUT ASSOCIATION OF LAND SURVEYORS, INC. ON AUG. 29, 2019. IT IS A TOPOGRAPHIC/BOUNDARY SURVEY AND IS BASED UPON A RESURVEY CONFORMING TO HORIZONTAL ACCURACY CLASS A-2 AND A VERTICAL ACCURACY OF CLASS T-2 AND IS INTENDED TO BE USED FOR THE PURPOSE OF SHOWING EXISTING CONDITIONS AND PROPERTY LINE INFORMATION. TO BEST OF MY KNOWLEDGE AND BELIEF THIS MAP IS SUBSTANTIALLY CORRECT AS NOTED HEREON.

A. RAFAEL MARTINEZ
LICENSED LAND SURVEYOR
DATE: 11/10/21

THIS MAP IS NOT VALID WITHOUT A LIVE SIGNATURE

NO.	DATE	REVISIONS	BY	CHK	APPV
1	8-10-2022	REVISION PER CLIENT COMMENTS	JMW	GRR	JPB
2	3-17-2022	ADDITIONAL TOPO AND UTILITIES UPDATE PER MARKUP	JT	GRR	JPB

DRAWN BY: JT
CHECKED BY: JPB
SCALE: 1"=40'
DATE: 11-10-2021

BOUNDARY/TOPOGRAPHIC SURVEY
EXISTING CONDITIONS PLAN

JOB NO.	DRAWING NUMBER	SHEET
2021-267	2021-267 Montville Water Tank.dwg	1 OF 1