

DESAUTEL'S RESUBDIVISION

CHESTERFIELD ROAD, MONTVILLE, CONNECTICUT



GENERAL NOTES:

- 1) Reference is made to the following plans:
 A) Survey filed for Michael Desautels, North of 237 Chesterfield Road, Town of Montville, Connecticut, Date: 8/30/2018. Plan surveyed and mapped by C.A. Engineers. Plan filed on the Montville Land Records Map 2712.
 B) "As-Built Location Survey, Prepared For Summar-Raf Builders, LLC, #225 Chesterfield Road, Montville, Connecticut, Dated: 4/10/18, Scale: 1"=10'." Plan surveyed and mapped by Advanced Surveys, LLC. Plan found in the Montville Building Department.
 C) "Final Subdivision Plan, Forest View Estates, Owner & Developer, Alejo Ortega, Scale: 11"=40', Dated: May 1978, Black Ash Rd., Montville, Conn. Sheet 2 & 4 of 11." Plan surveyed and mapped by Seaboard Engineering Corp., Mianit, Conn. Plan filed on the Montville Land Records Map 74 & 76.
 D) Columbus Waterford R.O.W., Land To Be Purchased From Julius Borokowski And Thomas Brown, Montville, Conn. Plan filed on the Montville Land Records Map 2712.
 E) "Columbia - Waterford R.O.W., Map Showing Land To Be Purchased From First Acme Corp., Montville, Conn., The Hartford Electric Light Co., General Engineering Department Scale: 1"=100', Date: 10-4-66, No. M102705, Sheet 1." Plan certified by John Luchs, Jr. and provided to Florek Surveying LLC by Eversource.
- 2) Not all underground utilities have been shown. Call before you dig (CBYD) is recommended prior to any construction.
- 3) North orientation is based on an RTK GNSS observation under 2 different satellite constellations utilizing a Carlson BRX-6 and the ACCORN Network in April 2021.
- 4) The word certify as used is understood to be an expression of professional opinion by the surveyor. It is a declaratory statement which is based on the surveyor's best knowledge, information and belief. As such, it constitutes neither a guarantee nor warranty, expressed or implied, of any information contained herein.
- 5) Wellheads field marked by James Cowen, CPSS and field located thereafter.
- 6) Reference is made to the following deed filed in the Town of Montville's Clerk's Office, Volume 649 Page 942 for the subject property.
- 7) The removal or destruction of survey monumentation, whether set or found, as shown on this survey plan may be subject to Connecticut Statute 47-34a.
- 8) Property is in the R-80 Zone.

SURVEY NOTES:

1. This survey has been prepared pursuant to the regulations of the Connecticut State Agencies, Sections 20-300b-1 through 20-300b-20 and the "Standards for surveys and maps in the State of Connecticut" Prepared and Adopted by the Connecticut Association of Land Surveyors, Inc. on August 29, 2019. This survey type is a RESUBDIVISION PLAN based on a RESURVEY as shown in GENERAL NOTES MAP REFERENCE 1a-e. It is intended to show a PROPOSED BUILDING LOTS.

2. This survey conforms to Class A-2 / T-2 / V-3
 To the best of my knowledge and belief this map is substantially correct as noted thereon.

John D. Florek 15 cts 11/4/23
 Brian D. Florek, L.L.S. #70135 Date
 Managing Member, Florek Surveying, LLC
 239 Shore Road, Waterford, CT 06385
 bflorek@floreksurveyingllc.com (860) 271-6006

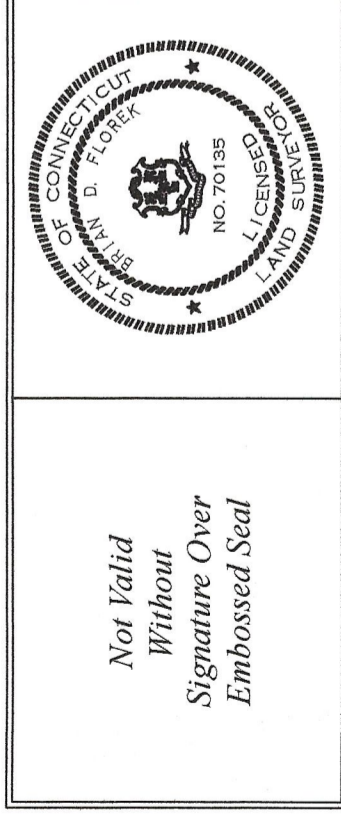

Not Valid
 Without
 Signature Over
 Embossed Seal

Date of Completion of All Work -

Approved by the Montville Planning and Zoning Commission:

Planning and Zoning Chairman or Secretary Date

Passive Solar Energy Techniques as Prescribed by Law Have Been Considered in Development of this Plan

Developer Date

Engineer Date

Erosion and Sediment Control Plan - Certified by the Montville Planning and Zoning Commission

Planning and Zoning Chairman or Secretary Date

Date of completion for all work:

TABLE OF CONTENTS:

- Sheet 1: Overall Plan
- Sheet 2: Existing Conditions
- Sheet 3: Conceptual Development Plan
- Sheet 4: Conceptual Development Plan
- Sheet 5: Details & Typicals

Applicant: Michael A. Desautels
 Mailing Address: 237 Chesterfield Road, Montville, CT

Phone: 860-912-8303

Email: desautels_mike@yahoo.com

Owner: Zachary Cash

Mailing Address: 257 Chesterfield Road, Montville, CT

Phone: 860-235-1813

Email: zachcash22@gmail.com

"This plan was compiled from other maps, record research or other sources of information. It is not to be construed as having been obtained as the result of a field survey, and is subject to such change as an accurate field survey may disclose."

GENERAL NOTES:

- 1) North orientation is based on an RTK observation utilizing the SUPERIOR Network in February of 2021.
- 2) Not all underground utilities, if any, are shown on this plan. Call before you dig is recommended prior to any construction activities.
- 3) The word certify as used is understood to be an expression of professional opinion by the surveyor. It is a declaratory statement which is based on the surveyor's best knowledge, information and belief. As such it constitutes neither a guarantee nor warranty, expressed or implied, of any information contained hereon.

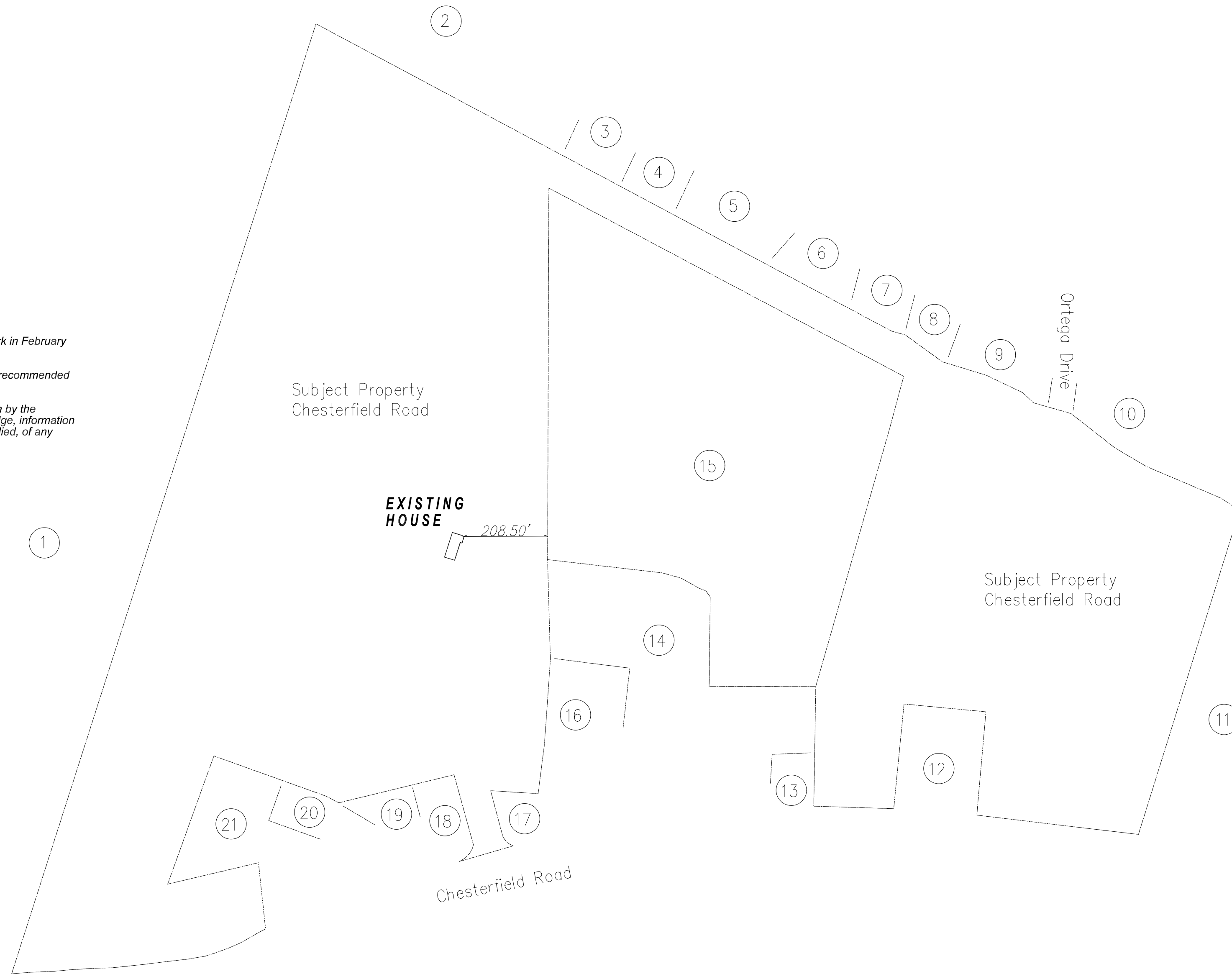

Abutting Property Owners:

#	Parcel Number	Owner Name	Co Owner Name	Property Address
1	021-001-000	HOWARD ROBERT A & PAMELA A		311 CHESTERFIELD RD
2	029-057-000	SMIAROWSKI EDWARD S & ROBYN L		271 CHESTERFIELD RD
3	029-058-000	NAZARKO THOMAS & DIANE		267 CHESTERFIELD RD
4	029-059-000	ANGELUS FRANK D & ANJANETTE M		263 CHESTERFIELD RD
5	029-060-000	TERRACCIANO DANIEL A		259 CHESTERFIELD RD
6	029-061-000	DELACRUZ ANITA		253 CHESTERFIELD RD
7	029-062-000	CIL REALTY INCORPORATED		245 CHESTERFIELD RD
8	029-062-001	DESAUTELS MICHAEL A & TERRI		237 CHESTERFIELD RD
9	029-063-000	CLARK NANCY A		229 CHESTERFIELD RD
10	029-064-000	FALCON JUAN MANUEL & TARA LEE		225 CHESTERFIELD RD
11	029-065-000	HUBBERT NANCY ANNE		213 CHESTERFIELD RD
12	029-067-000	CONNECTICUT LIGHT & POWER COMPANY		BLACK ASH RD
13	029-069-00A	BRYCKI MICHAEL S SR & MARIAN T TRSTES	BRYCKI FAMILY LIVING TRUST	132 BLACK ASH RD
14	029-088-000	JOB CHRISTEN E	(WALENCZYK HARRY S & ELIZABETH C LUJ)	124 BLACK ASH RD
15	029-089-000	PONTON FRANCES J		118 BLACK ASH RD
16	029-107-000	ROSS JOSEPH WILLIAMS		25 CARIBOU WAY
17	029-108-000	CHARLES R & DIANNE E SWIFT JONATHAN A		23 CARIBOU WAY
18	029-109-000	KOPIU TADEUSZ JR & CHARLENE F		17 CARIBOU WAY
19	029-110-000	JONES DWIGHT W JR & ERIKA SWAN		11 CARIBOU WAY
20	029-112-000	SANTACROCE CYNTHIA E		46 ORTEGA DR
21	029-113-000			45 ORTEGA DR

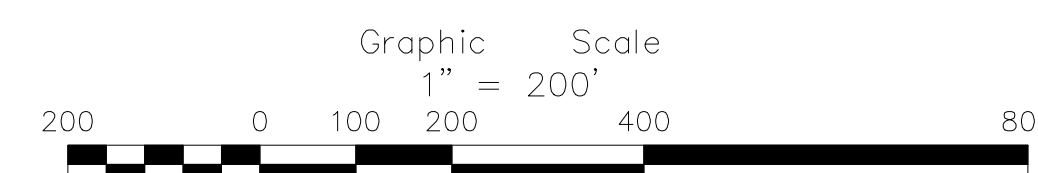

COMPILATION SURVEY
 PLAN PREPARED FOR
ZACHARY F. CASH
CHESTERFIELD ROAD
MONTVILLE, CONNECTICUT
ZONE: R - 80
 SCALE: 1" = 200'
 DATED: NOVEMBER 11, 2023

LEGEND

- These standard symbols may be found in the drawing.
- ★ Light Pole
 - CDNC. Concrete
 - BIT. Bituminous
 - ∅ Utility Pole
 - WV Water Valve
 - GV Gas Valve
 - X - Chain Link Fence
 - - - Boundary Line
 - Edge of Road / Drive
 - Stone Wall
 - CB Catch Basin
 - SMH Sewer Manhole
 - I.P.S. 5/8" Iron Pin Set
 - RR SPIKE FOUND Railroad Spike Found
 - D.H.F. Drill Hole Found
 - D.H.S. Drill Hole Set
 - WLF 2 Wetland Flag
 - GMS Granite Merestone
 - EX. CDNC. MDN. Existing Concrete Monument
 - T.B.S. To Be Set
 - CHD CT Highway Department Monument
 - - - Existing Contour Line
 - BCLC Bit Conc. Lipped Curbing

NOW OR FORMERLY
Michael A. & Terri Desautels
237 Chesterfield Road
Town Clerk Volume 639 Page 21
Tax Assessor Map 29 Lot 62-001

NOW OR FORMERLY
Nancy A. Clark
229 Chesterfield Road
Town Clerk Volume 471 Page 75
Tax Assessor Map 29 Lot 63

NOW OR FORMERLY
Nancy Anne Hubbert
213 Chesterfield Road
Town Clerk Volume 326 Page 841
Tax Assessor Map 29 Lot 63

NOW OR FORMERLY
Juan & Tara Lee Falcon
225 Chesterfield Road
Town Clerk Volume 634 Page 947
Tax Assessor Map 29 Lot 64
Map Reference 1?

NOW OR FORMERLY
Connecticut Light & Power Company
Black Ash Road
Town Clerk Volume 149 Page 108
Tax Assessor Map 29 Lot 67

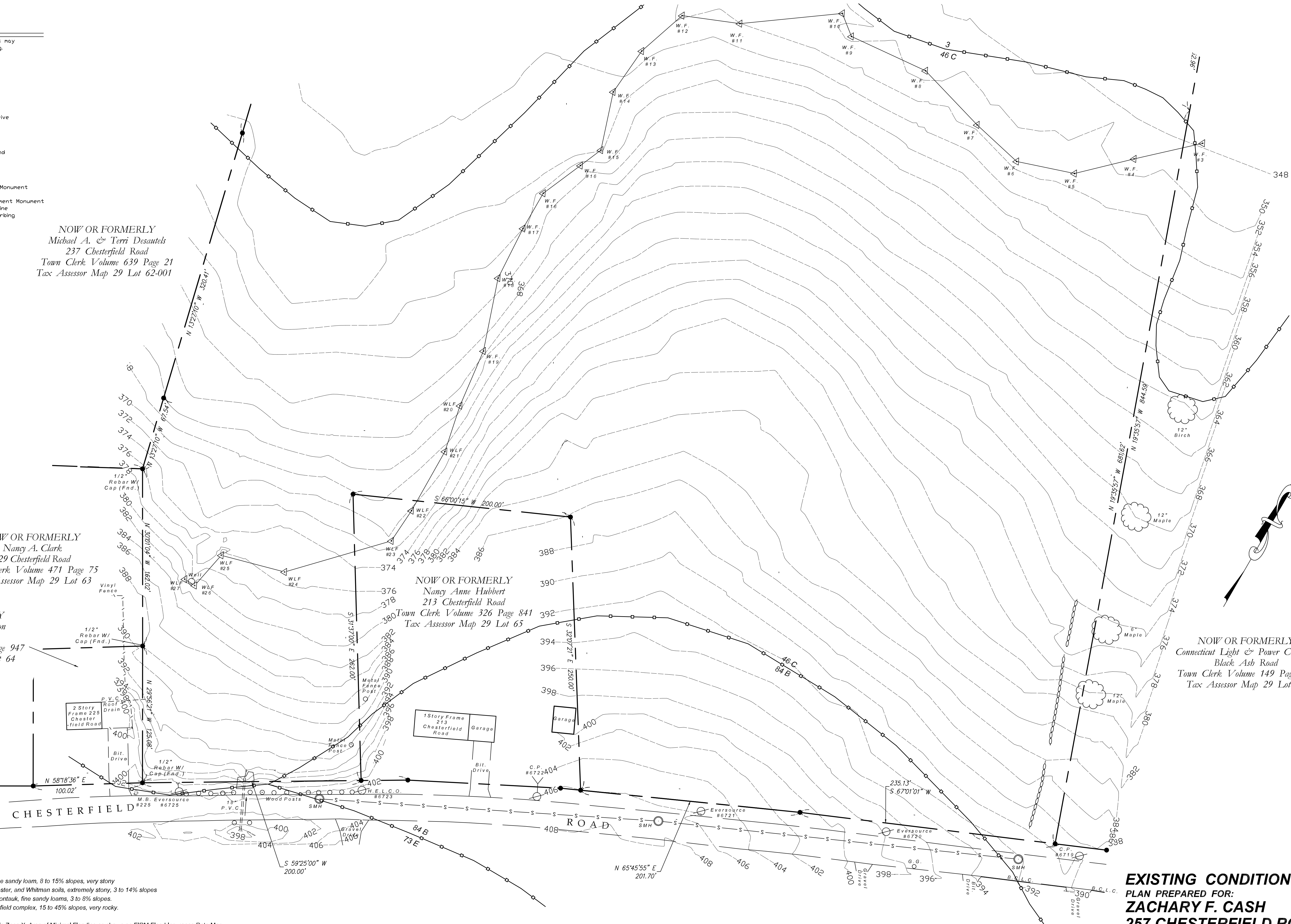

- NOTES:**
- 1) Soil Classifications:
 - a. 46C Woodbury, fine sandy loam, 8 to 15% slopes, very stony
 - b. 3 Ridgbury, Leicester, and Whitman soils, extremely stony, 3 to 14% slopes
 - c. 84B Paxton and Montauk, fine sandy loams, 3 to 8% slopes.
 - d. 73E Charlton-Chatfield complex, 15 to 45% slopes, very rocky.
 - 2) Area of proposed construction is Zone X, Area of Minimal Flooding as shown on FIRM Flood Insurance Rate Map, New London County, Connecticut, All Jurisdictions, Panel 333 of 554, Community: Town Of Montville, Number 090099, Panel 333, Suffix G. Map Effective Date: July 18, 2011.

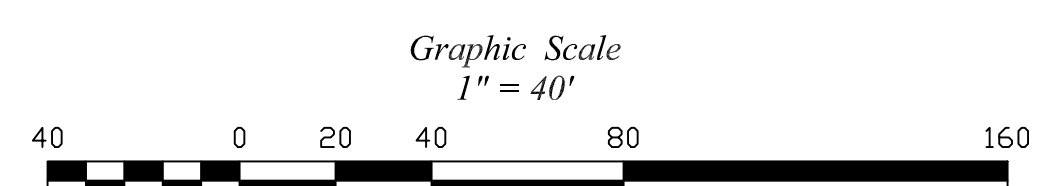

EXISTING CONDITIONS SURVEY
PLAN PREPARED FOR:
ZACHARY F. CASH
257 CHESTERFIELD ROAD
MONTVILLE, CONNECTICUT
SCALE: 1" = 40'
OCTOBER 9, 2023

LEGEND

These standard symbols may be found in the drawing.

- ★ Light Pole
- CDNC. Concrete
- BIT. Bituminous
- U Utility Pole
- WV Water Valve
- GV Gas Valve
- X - Chain Link Fence
- Boundary Line
- Edge of Road / Drive
- Stone Wall
- CB Catch Basin
- SMH Sewer Manhole
- I.P.S. 5/8" Iron Pin Set
- RR SPIKE FOUND Railroad Spike Found
- D.H.F. Drill Hole Found
- D.H.S. Drill Hole Set
- WLF 2 Wetland Flag
- GMS Granite Merestone
- EX. CDNC. MDN. Existing Concrete Monument
- T.B.S. To Be Set
- CHD CT Highway Department Monument
- - - Existing Contour Line
- BCLC Bit Conc. Lipped Curbing

NOW OR FORMERLY
Michael A. & Terri Desautels
237 Chesterfield Road
Town Clerk Volume 639 Page 21
Tax Assessor Map 29 Lot 001

NOW OR FORMERLY
Nancy A. Clark
229 Chesterfield Road
Town Clerk Volume 471 Page 75
Tax Assessor Map 29 Lot 63

NOW OR FORMERLY
Juan & Tara Lee Falcon
225 Chesterfield Road
Town Clerk Volume 634 Page 947
Tax Assessor Map 29 Lot 64
Map Reference 1?

NOW OR FORMERLY
Nancy Anne Hubbard
213 Chesterfield Road
Town Clerk Volume 326 Page 841
Tax Assessor Map 29 Lot 65

NOW OR FORMERLY
Connecticut Light & Power Company
Black Ash Road
Town Clerk Volume 149 Page 108
Tax Assessor Map 29 Lot 67

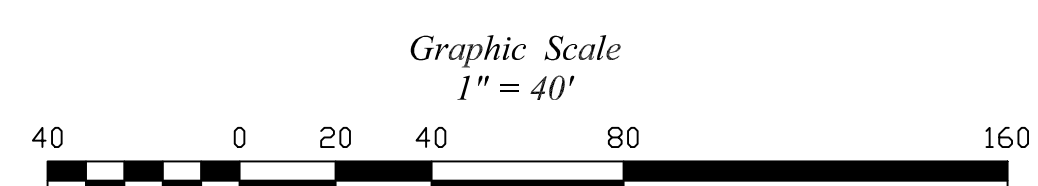

RESUBIVISION SURVEY
PLAN PREPARED FOR:
ZACHARY F. CASH
257 CHESTERFIELD ROAD
MONTVILLE, CONNECTICUT
SCALE: 1" = 40'
OCTOBER 9, 2023

LEGEND

These standard symbols may be found in the drawing.

- ★ Light Pole
- CDNC. Concrete
- BIT. Bituminous
- ⊕ Utility Pole
- WV Water Valve
- GV Gas Valve
- X - Chain Link Fence
- Boundary Line
- Edge of Road / Drive
- Stone Wall
- CB Catch Basin
- SMH Sewer Manhole
- I.P.S. 5/8" Iron Pin Set
- RR SPIKE FOUND Railroad Spike Found
- D.H.F. Drill Hole Found
- D.H.S. Drill Hole Set
- WLF 2 Wetland Flag
- GMS Granite Merestone
- EX. CDNC. MDN. Existing Concrete Monument
- T.B.S. To Be Set
- CT Highway Department Monument
- Existing Contour Line
- BCLC Bit Conc. Lipped Curbing

NOW OR FORMERLY
Tadeusz J. Jr. & Charlene F. Kopu
11 Caribou Way
Town Clerk Volume 152 Page 320
Tax Assessor Map 29 Lot 110

NOW OR FORMERLY
Dwight W. Jones Jr. & Erica Swan
46 Ortega Drive
Town Clerk Volume 643 Page 314
Tax Assessor Map 29 Lot 112

NOW OR FORMERLY
Cynthia E. Santacroce
45 Ortega Drive
Town Clerk Volume 520 Page 216
Tax Assessor Map 29 Lot 113

NOW OR FORMERLY
Connecticut Light & Power Company
Black Ash Road
Town Clerk Volume 149 Page 108
Tax Assessor Map 29 Lot 67

NOW OR FORMERLY
Michael A. & Terri Desautels
237 Chesterfield Road
Town Clerk Volume 639 Page 21
Tax Assessor Map 29 Lot 62-001

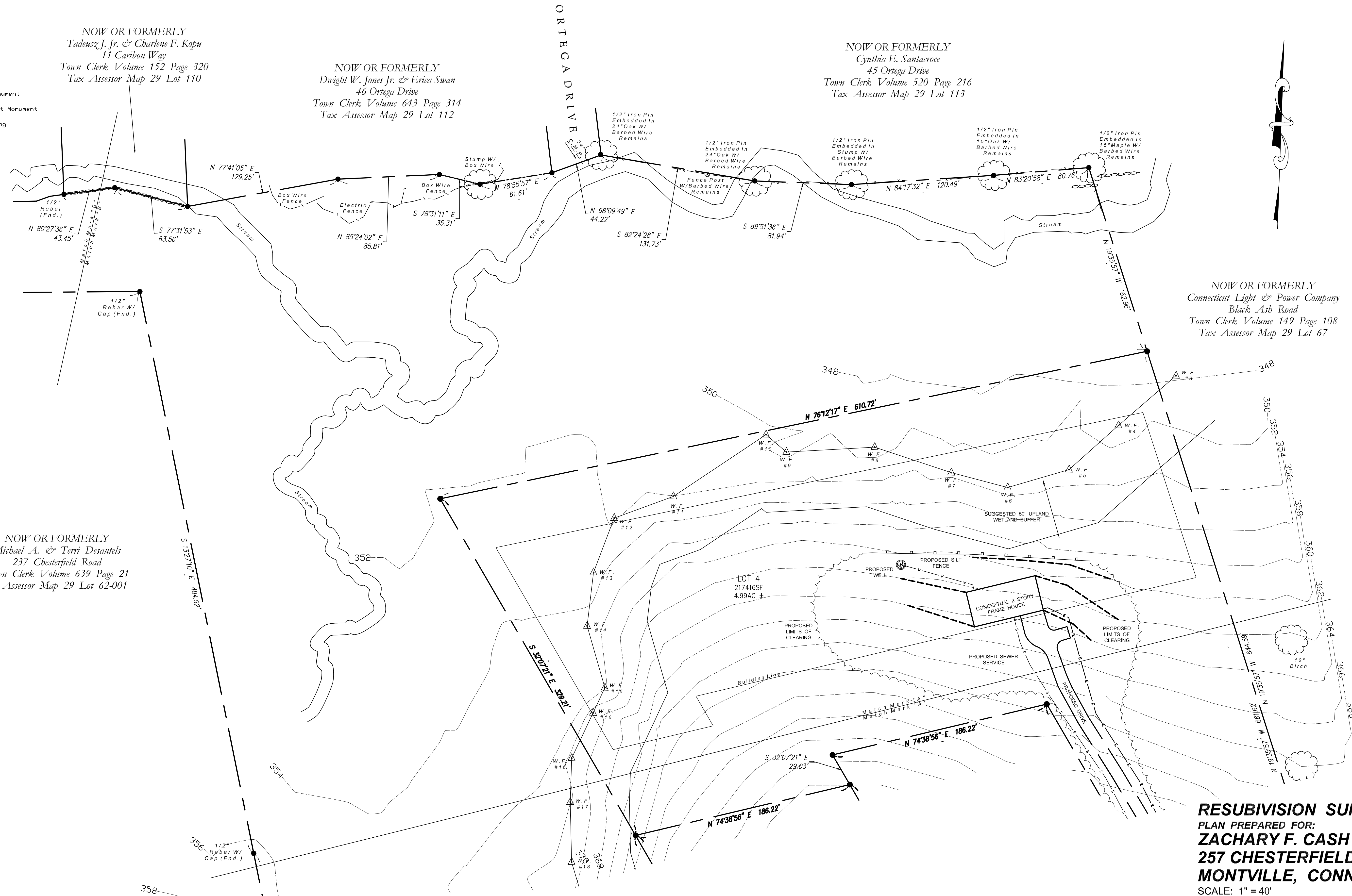

RESUBIVISION SURVEY
PLAN PREPARED FOR:
ZACHARY F. CASH
257 CHESTERFIELD ROAD
MONTVILLE, CONNECTICUT
SCALE: 1" = 40'
NOVEMBER 6, 2023

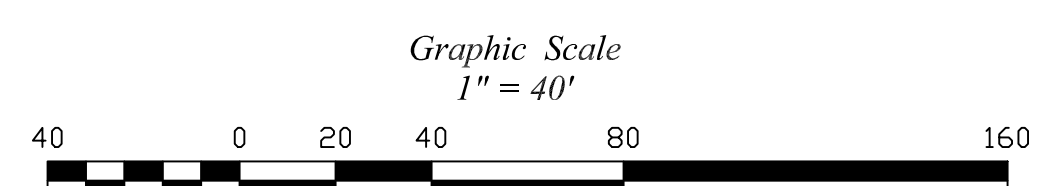

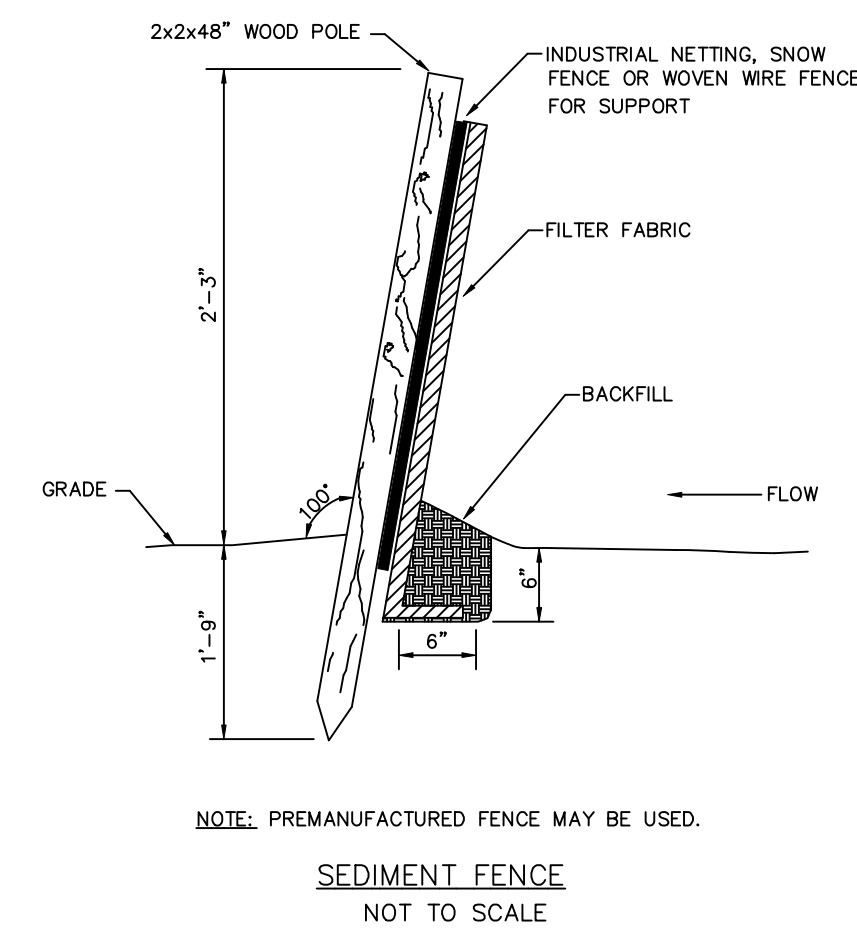

NOTE: PREMANUFACTURED FENCE MAY BE USED.

SANITARY SEWER SERVICE TRENCH DETAIL

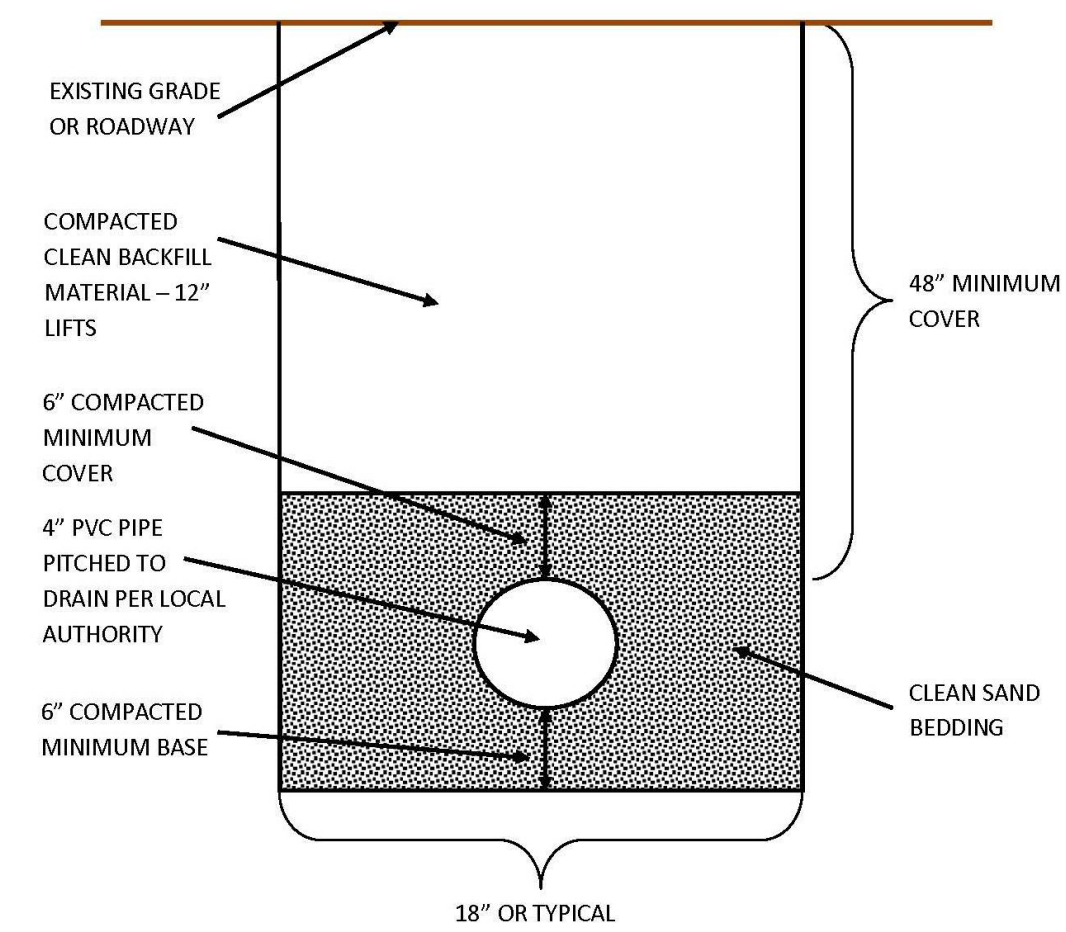

- NOTES:
1. SIZE OF SERVICE TO BE DETERMINED BY NEEDS OF STRUCTURE AND CUSTOMER. TYPICAL RESIDENTIAL CONNECTION DEPICTED.
 2. CONNECTION TO EXISTING SEWER LATERAL. CONFIGURATION OF THE SERVICE SHALL BE MADE PER SPECIFICATIONS OF LOCAL WATER UTILITY.

WATER SERVICE TRENCH DETAIL

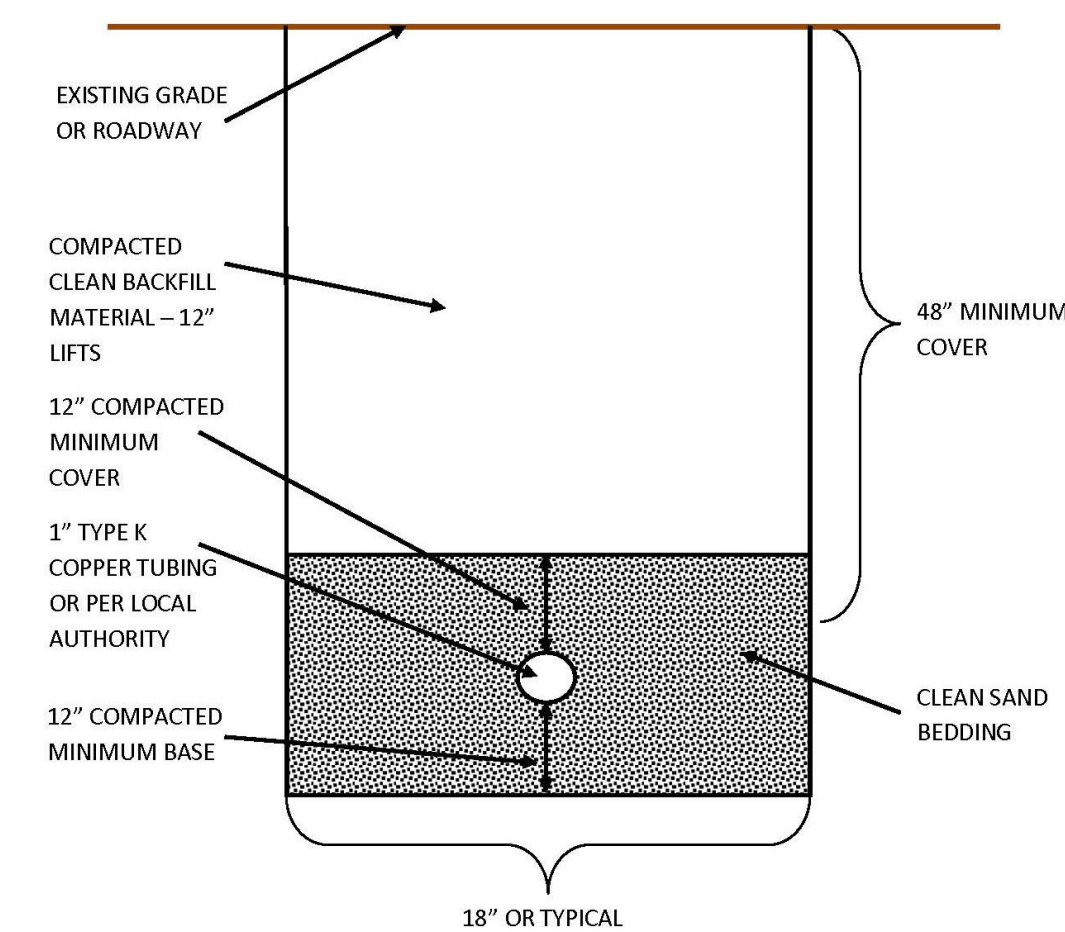

- NOTES:
1. SIZE OF SERVICE TO BE DETERMINED BY NEEDS OF STRUCTURE AND CUSTOMER. TYPICAL RESIDENTIAL CONNECTION DEPICTED.
 2. CONNECTION TO WATER MAIN AND CONFIGURATION OF THE SERVICE METER/VALVING SHALL BE MADE PER SPECIFICATIONS OF LOCAL WATER UTILITY. TYPICALLY SADDLE TAP FITTING AND CORPORATION STOP, SHUT OFF VALVE AND WATER METER.

ELECTRIC/COMMUNICATION UTILITY TRENCH

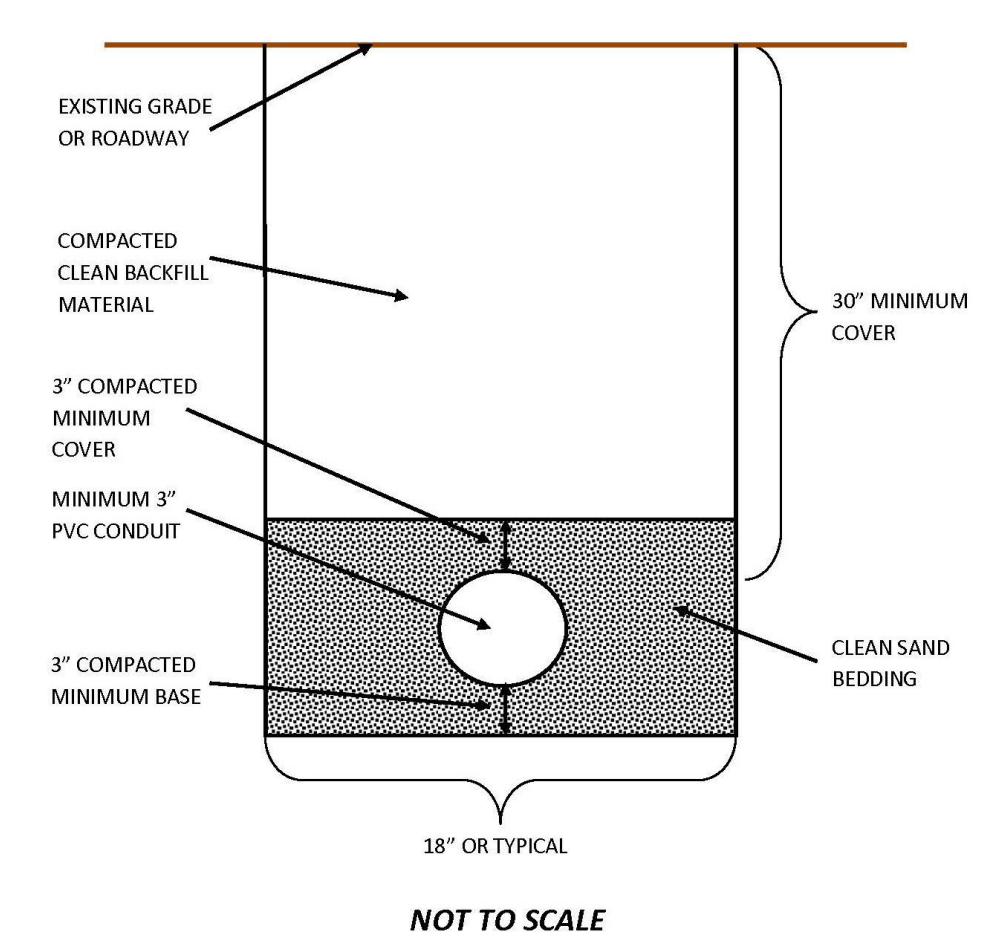

- NOTES:
1. CONDUIT AND SERVICE CONNECTIONS TO BE MADE PER LOCAL UTILITY SPECIFICATIONS AND REQUIREMENTS.

RESUBDIVISION PLAN
DETAILS & TYPICALS
 PROPERTY BELONGING TO:
ZACHARY F. CASH
257 CHESTERFIELD ROAD
MONTVILLE, CONNECTICUT
 NOVEMBER 6, 2023